

BLUEVOLUTION

Water to Water Modular Chiller and Heat Pump

EW(W)(H)(L)T~Q- A

For cooling and heating application

- Heat pump with inversion on water side
- Heat pump with inversion on refrigerant side
- Condenserless

R-32

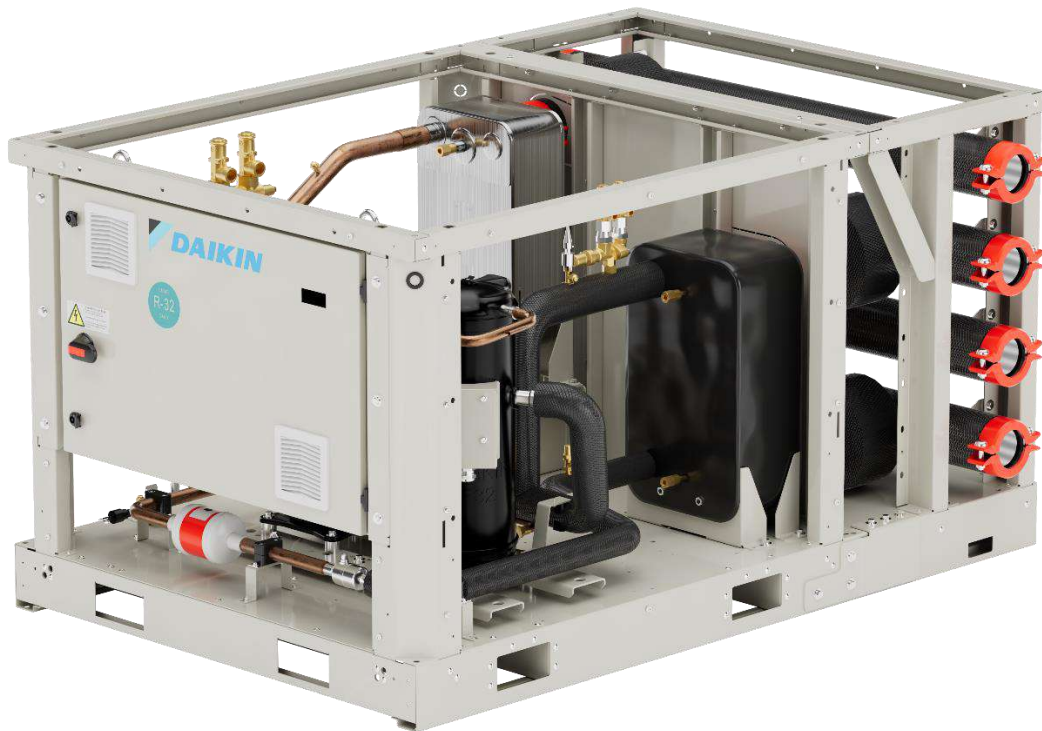

Index

1.	General Characteristics.....	3
2.	F-Gas Information	14
3.	Nomenclature	15
4.	Options.....	16
5.	Accessories.....	17
6.	Technical data	20
7.	Sound data	26
7.1	Gold Efficiency – Standard Sound.....	26
7.2	Gold Efficiency – Reduced Sound	28
8.	Electrical data.....	30
9.	System data.....	31
9.1	Two modules	31
9.2	Three modules	32
9.3	Four modules	33
9.4	Five modules.....	34
9.5	Six modules.....	34
9.6	Seven modules.....	34
9.7	Eight modules	34
10.	Operating Limits	35
11.	Water Quality	37
12.	Hydronics	38
12.1	Heat exchangers water volume and connection size	38
12.2	Module	38
12.3	Module with manifold kit.....	39
12.4	Pump module.....	40
12.5	Pump Modules technical data.....	41
13.	Heat recovery.....	42
14.	Installation notes.....	42
15.	Dimensional drawings.....	43
16.	Technical Specifications	46

1. General Characteristics

A new approach to system design

New Daikin EW_T~Q- introduce a different approach to system design. The series is composed of 3 base modules 100, 125 ,160 kW which can be combined to build a bigger unit. The flexible design makes possible to reach the required capacity optimizing the footprint and simplifying unit handling and transportation. The multiple circuits provide high reliability and easy maintenance.

The modules can be combined in array (max four) or stacked (max two).

single module



array (up to four)



two modules stacked



two arrays (up to four) stacked



The modular design makes possible to provide the required capacity optimizing the installation space. Other advantage is the possibility to easy increase the system capacity over the time simply adding new modules to the system, in this way is possible to allocate capacity when required distributing the investment cost over the time as the required capacity increase.

Compare to a large package unit the refrigerant charge is divided in multiple smaller circuit reducing the risk of refrigerant loss due to leakage.

Pump modules are available to build a complete system.

The power supply can be separated per each module or can be grouped up to four modules, so up to 600 kW with single power supply.

Unit configuration

The new Modular by Daikin is available in the following versions:

- Water to Water reversible on water side (100, 125, 160 kW)
- Water to Water reversible on refrigerant side (100 KW)
- Condenserless (requires remote condenser) (100, 125, 160 KW)

Each module is available in two versions:

- XS → High Efficiency, Standard Sound
- XR → High efficiency, Reduced Sound (Suitable for outdoor installation)

Low environmental impact

F-GAS regulation, entered into force in 2015, set up a phase down program for traditional HFC's refrigerants. In 2018 first significant reduction step has been introduced (37%) and in 2030 the reduction (calculated in equivalent CO2 tons) will need to achieve almost 80%.

Daikin BLUEEVOLUTION chillers uses R-32 refrigerant to reduce drastically the carbon footprint of the unit. The selection of R-32 (chemical name difluoromethane) minimizes the global warming impact of scroll compressor chillers thanks to the lower Global Warming Potential in combination with high-energy efficiency.

The Global Warming Potential of R-32 is 675, which is only one third of HFC R-410A. Thanks to the lower flammability classification (R-32 refrigerant is classified A2L in ISO817), it can be safely used in many applications including chilled water systems. Being a single component refrigerant, R-32 is also easier to recycle and reuse, that is another environmental plus in its favor.

Daikin has a long history of continuous reduction of the environmental impact of cooling, heating, and refrigeration, having a unique expertise that comes from manufacturing both refrigerants and equipment. This position is one of the results of company's corporate philosophy to "Be a Company that Leads in Applying Environmentally Friendly Practices".

Regarding refrigerant choice, Daikin has expertise in using fluorinated (HFC, HFO) as well as non-fluorinated gases (ammonia, carbon dioxide, hydrocarbons) because the company believes in diversity of refrigerant choice to allow the best suited solution to be used in each application.

Compared to other low GWP alternatives to R410A available on the market, R32 provides the best combination of direct and indirect emissions. Other alternative available on the market is R454B, but despite a lower GWP the sum of direct and indirect emission result higher.

	Reference R410A	R32	R454B
Global Warming Potential (GWP)	2088	675	466
Composition	R32 50% R125 50%	R32 100%	R32 68,9% R1234yf 31,1%
Blend	YES	NO	YES
Refrigerant Safety Classification	A1	A2L	A2L
Temperature Glide	< 0,1	0	≈ 1,3
Capacity	100	110 (10% more than 410A)	97 (3% less than 410A)
Efficiency	100	107 (7% more than 410A)	102 (2% more than 410A)
Refrigerant Charge	100	60 (40% less than 410A)	90 (10% less than 410A)
Direct Emissions kg CO₂ – eq.	1879	496	346
Indirect Emissions kg CO₂ – eq.	15384	14419	14662
Total Emissions kg CO₂ – eq.	17263	14916 (best!)	15008

Thanks to lower refrigerant charge required and higher efficiency (lower power consumption) of R32, the total equivalent emission of CO₂ is lower than R454B even if GWP is higher.

High efficiency

The new Daikin Modular features high efficiency at both full load and part load to ensure the lowest energy consumption reducing CO₂ indirect emission as well as running cost.

Outstanding reliability

Each module has one refrigerant circuit, combining “n” modules the resulting system have “n x circuits” truly independent from each other allowing the system to operate with a module down and eventually extract and replace the module without affecting the operation of the others.

Outdoor Installation

The modules in XR version are suitable for outdoor installation (refer to IOM for details on installation requirements)

Code requirements – Safety and observant of laws/directives

All units are designed and manufactured in accordance with the following directives and harmonized standards:

Low voltage directive	DIRECTIVE 2014/35/EU
Electromagnetic compatibility (EMC)	DIRECTIVE 2014/30/EU
Machinery directive	DIRECTIVE 2006/42/EC
Pressure equipment design	DIRECTIVE 2014/68/EU
Ecodesign	DIRECTIVE 2009/125/EC
Safety of machinery	EN 60204-1
EMC - Part 6-2	EN 61000-6-2
EMC - Part 6-4	EN 61000-6-4
Safety and environmental requirements	EN 378-1; EN 378-2; EN 378-4
Methods for calculation pressure relief devices.	EN 13136

Certifications

Units are CE marked, complying with European directives in force, concerning manufacturing and safety.

Compressors

Hermetic orbiting scroll type optimized for R-32 operation and complete with motor over-temperature and over-current protection devices. Each compressor is equipped with an oil heater that keeps the oil from being diluted with the refrigerant when the chiller is not running. The compressors are connected in Tandem, configuration on each refrigerant circuit. Each compressor is mounted on rubber antivibration mounts for a quiet operation. Unit is delivered with complete oil charge.

Evaporator

The unit is equipped with a direct expansion plate-to-plate type evaporator optimized for R-32 refrigerant operation. This heat exchanger is made of stainless-steel brazed plates and is covered with 20mm closed cell insulation material. The evaporator water connections are provided with Victaulic kit (as standard). The evaporator is manufactured in accordance with 2014/68/EU. The evaporator flow switch and the evaporator water filter are available as option. Note the installation of flow switch and filter is mandatory. (Reduced Sound version includes the electric heater on the evaporator).

Condenser

The unit is equipped with a direct expansion plate-to-plate type condenser optimized for R-32 refrigerant operation. This heat exchanger is made of stainless-steel brazed plates. Water connections are provided with Victaulic kit (as standard). The condenser is manufactured in accordance with 2014/68/EU. The flow switch and filter are available as option. (Reduced Sound and EWHT include 20mm condenser insulation).

Electronic expansion valve

The unit is equipped with electronic expansion valves to achieve precise control of R-32 refrigerant mass flow. As today's systems require improved energy efficiency, accurate temperature control, wide range of operating conditions, the application of electronic expansion valves becomes mandatory.

Electronic expansion valves have unique features: short opening and closing time, high resolution, positive shut-off function to eliminate use of additional solenoid valve, continuous modulation of mass flow without stress in the refrigerant circuit and corrosion resistance stainless steel body. If compared to traditional thermostatic valves, electronic expansion valves allow the system to work with low condenser pressure (wintertime) without any refrigerant flow problems and the perfect control of the chilled water temperature.

Refrigerant circuit

Each unit has one refrigerant circuit and each one includes:

- Compressor
- Refrigerant
- Evaporator
- Condenser
- Electronic expansion valve
- Sight glass with moisture indicator
- Filter drier
- Charging valves
- High pressure switch
- High pressure transducers
- Low pressure transducers
- Oil pressure transducer
- Suction temperature sensor

Electrical panel

The main panel is fitted with a main switch interlocked door that shuts off power supply when opening.

EWWT_Q-XS, EWHT_Q-XS and EWLT_Q-XS are suitable for indoor installation.

EWWT_Q-XR, EWHT_Q-XR and EWLT_Q-XR are suitable for indoor and outdoor installation.

Controller

The controller will be installed as standard and it will be used to modify unit set-points and check control parameters.

- A sophisticated software with predictive logic, will select the most energy efficient combination of compressors, EEXV to keep stable operating conditions to maximize unit energy efficiency and reliability.
- The controller will be able to protect critical components based on external signals received from the unit itself.

Modular design

Traditionally European market is composed for the most part by package units (chiller and heat pumps), with manufactures providing different sizes scaling up compressors and heat exchangers to cover from small capacities up to medium and large. Modular market was mainly driven by Asian countries.

Recently the market saw a growth of modular applications also in Europe and US. The concept behind modular market is the idea of combining few small chiller sizes connected on hydraulic and control to reach larger capacities. So, instead of a large chiller the system is composed by many smaller size chillers piped together and controlled as a single bigger unit.

Modular design introduces many advantages:

- High full load and part load efficiency
- Easy transportation and handling
- Reliability
- Smaller refrigerant charge per circuit
- Lower starting current
- System capacity can be increased over the time
- Lower noise at part load

High full load and part load efficiency

Is well known that systems run most of the type unloaded compare the design conditions. The capacity of the unit to follow the load determinates it's efficiency at part load.

We can compare a package chiller vs modular design to see the difference:

Capacity required 480 kW

Two solutions:

- Package chiller
- Modular Chiller

Package chiller

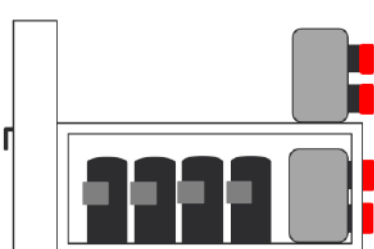
Package unit			Size ..	Size X	Size Y	Size ..
	Capacity	kW	...	460	510	...
	Compressors/circuits	n°/n°	...	4/2	4/2	...
	Capacity Steps	n°	...	4	4	...
	Min capacity	%	...	25	25	...
	Length	mm	...	2400	2400	...
	Width	mm	...	800	800	...
	Height	mm	...	1800	1800	...

Package range have different sizes with different compressors and heat exchanger. The size to be selected is the one proving same or more capacity than what is required by design. In this case, to satisfy the requirement the size Y is required.

Modular chiller

3 Modules			
 <p>Array of 3 w/manifold</p>	Capacity	kW	498
	Compressors/circuits	n°/n°	6/3
	Capacity Steps	n°	6
	Min capacity	%	17%
	Length	mm	1300
	Width	mm	3600
	Height	mm	1000

To compare the two solutions, we can consider the load profile from EN14825 for comfort cooling application. According to the standard if the capacity delivered is within $\pm 10\%$ than required the load is considered satisfied otherwise the unit must cycle between two stages UP and DOWN. The cycled operation introduce inefficiency so, the closer is the capacity delivered to the load the higher the efficiency at part load will be.

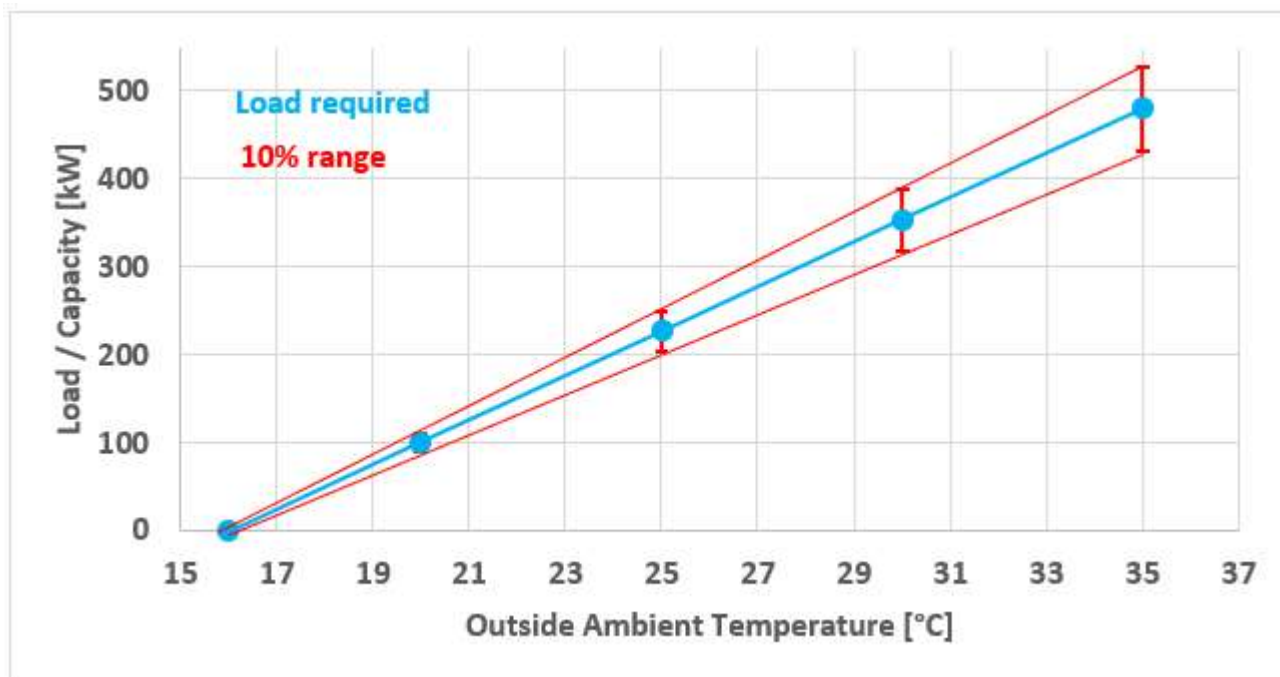

In part load condition the package chiller cannot deliver the required load within +/-10% range. This means that chiller will cycle between stage UP and stage DOWN introducing inefficiency in the operation.

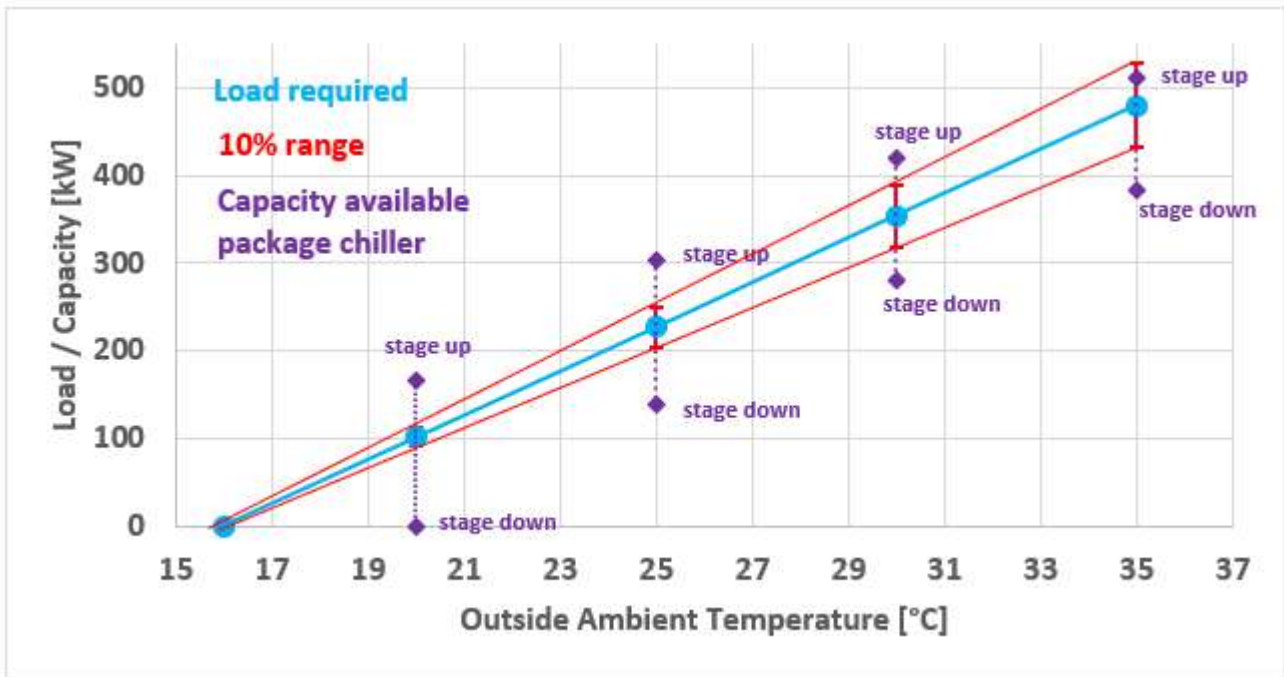

The Modular chiller (in this case three modules) can follow closely the load required without need of cycling.

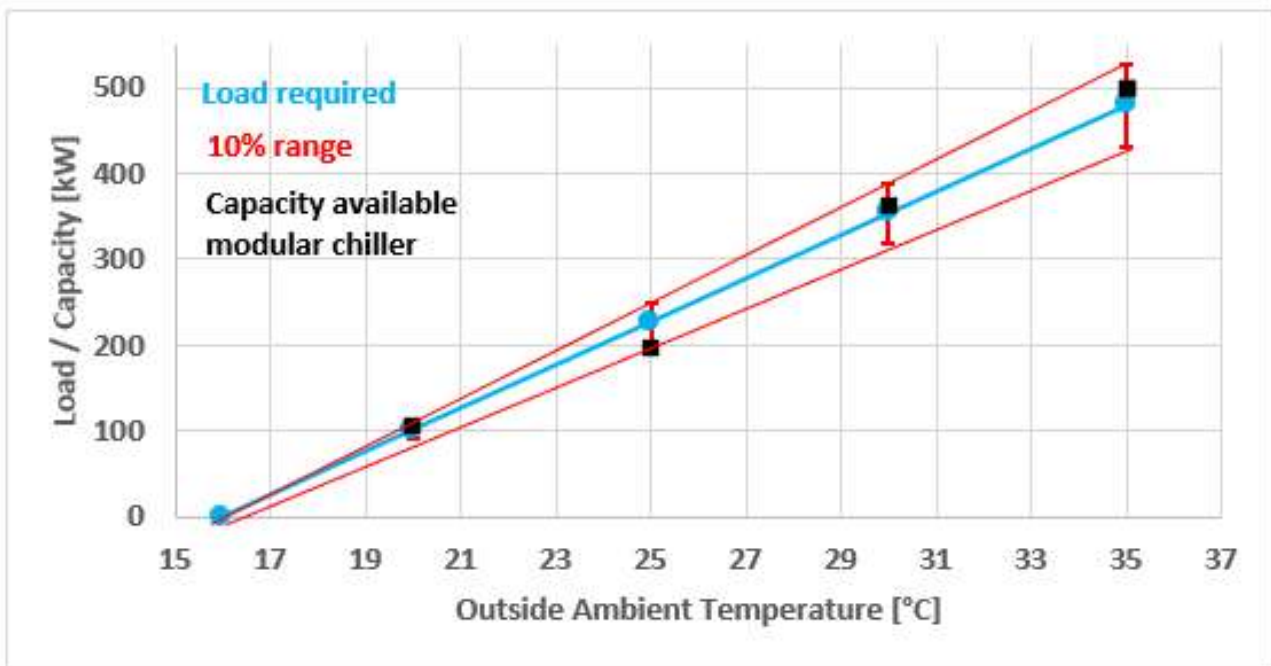

define one proving same or more capacity than what is required by design. In this case, to satisfy the requirement the size Y is required.

Easy transportation and handling

Modular units make possible to optimize transportation space reducing cost.

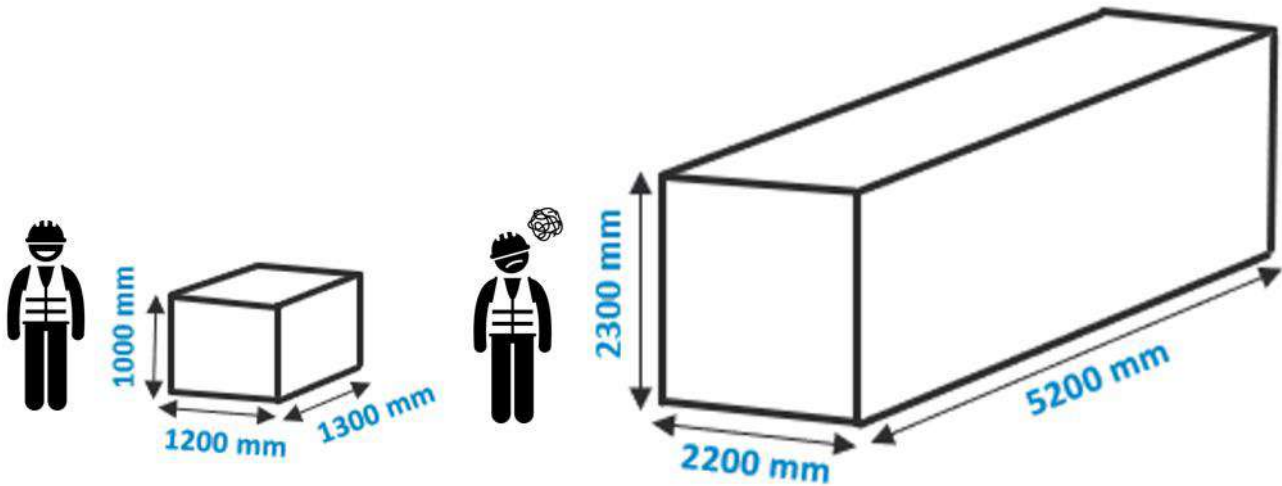



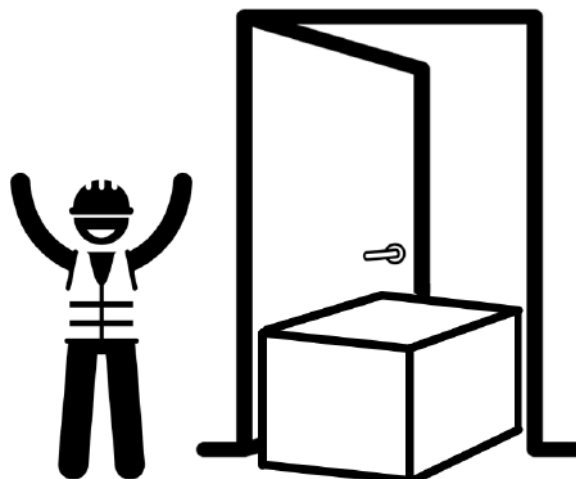

To handle and install large capacity chillers can be challenging due to space limitation and access restrictions to the site. Indoor units are fitted into mechanical room, large chillers do may not step through standard doors. With modular unit handling and transportation is easier and in case of retrofit. Considering for example installation a package large chiller: it results more difficult to handle and may requires construction works to be installed, while the single modules can be handled easily and assembled in the mechanical room.



The eight modules can be assembled in a way to best fit the space in the mechanical room. Regardless the position of the modules the control will manage the modules as a single large unit with multiple circuits.

See some examples below:

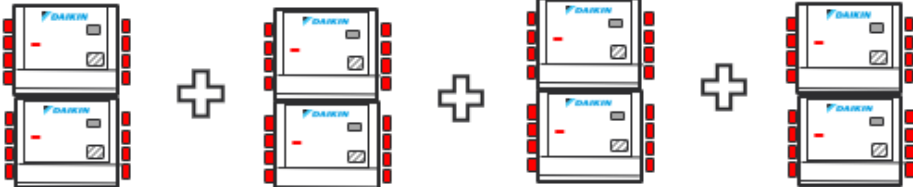
<p>option 1</p>	
<p>option 2</p>	
<p>option 3</p>	
<p>option 4</p>	
<p>option 5</p>	

NOTE: modules must be connected in parallel hydraulically

Reliability

The modular system operates as a single unit with multiple independent circuits. The same could be said about a package unit with multiple refrigerant circuits, but there is a big difference. Even if the refrigerant circuits are independent in case of major failure the entire unit stop, while a system made of multiple modules as full redundancy of any component per each circuit.

So, if major failure happens to a module, it can be stopped and eventually replaced without affecting the operation of the other modules.



Smaller refrigerant charge per circuit

Large package units contain large amount of refrigerant per circuit. In case of leakage in one circuit large quantity of refrigerant can be lost.

In modular units the same capacity is achieved with multiple smaller circuit containing smaller quantity of refrigerant. In case one module has leakage the amount of refrigerant loss is much smaller.

System capacity can be increased over the time

Modular design makes easy to increase the capacity installed of the system over the time. Many installations do not need the full design capacity from the start; commercial building with spaces for rent may increase capacity requirements as the spaces are occupied, or large project divided in phases. This makes possible to spread the investment over the time while with large package units the full capacity must be installed from the start with full cost even if not required.

Lower noise at part load

Noise emission form package units depends on number of compressors running and their rotational speed in driven by inverter.

Modular systems use more but smaller compressors. At low capacities modular chiller can achieve lower noise, also the flexibility on installation makes possible to reduce noise impact.

2. F-Gas Information

Additional information related to F-GAS Regulation (EU) No 517/2014 of the European Parliament and of the Council of 16 April 2014 on fluorinated greenhouse gases and repealing Regulation (EC) No 842/2006.

Model	Ref. type	Ref. GWP	N° of circuits	Ref. charge circuit #1 [kg] ⁽¹⁾	Ref. charge circuit #1 (TCO ₂ Eq)
EWWT100Q-XSA1	R32	675	1	6,0	4,8
EWWT125Q-XSA1	R32	675	1	7,1	4,8
EWWT160Q-XSA1	R32	675	1	9,1	6,2
EWHT100Q-XSA1	R32	675	1	7,0	4,8
EWWT100Q-XRA1	R32	675	1	6,0	4,8
EWWT125Q-XRA1	R32	675	1	7,1	4,8
EWWT160Q-XRA1	R32	675	1	9,1	6,2
EWHT100Q-XRA1	R32	675	1	7,0	4,8

i) The above data are referred to the unit without additional optional.

ii) All the data are subject to change without notice. For updated information on project base refer to Chiller Selection Software and unit's certified drawing Refrigerant charge values are for indication only and not considered binding. Refer to unit nameplate for specific unit refrigerant charge.

EWLT models are shipped with Nitrogen holding charge.

3. Nomenclature

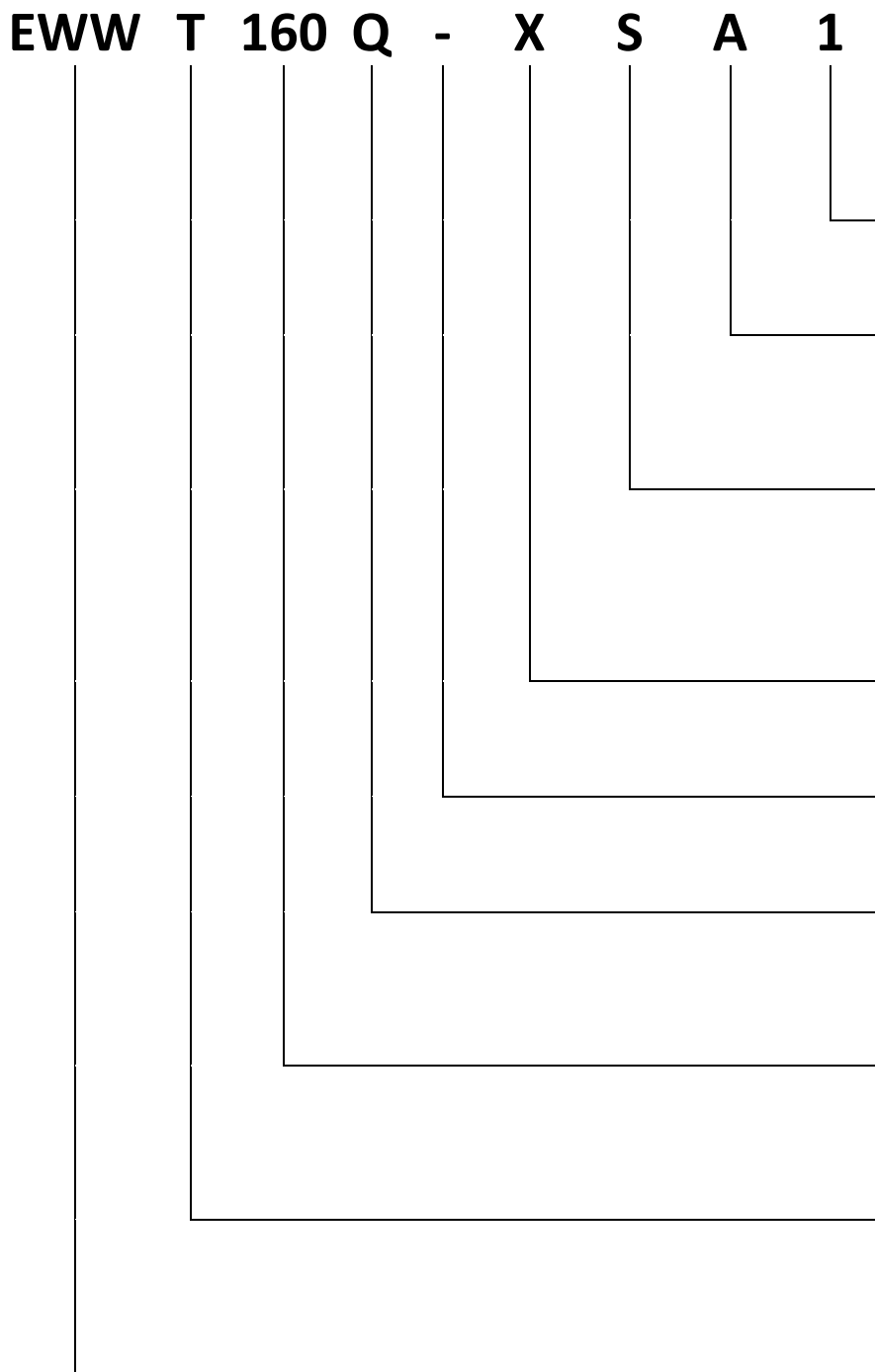

Digit 13: Number of independent refrigerant circuit

1

Digit 12: series revision

A = first revision

Digit 11: Sound Configuration

S = Standard Sound

R = Reduced Sound

Digit 10: Efficiency tier

X = Gold

Digit 9: Compressor control

- = without VFD

Digit 8: Range

Q = Modular Scroll

Digit 5 -7: capacity in kW at standard conditions

100, 125, 160

Digit 4: Refrigerant

T = R32

Digit 1 – 3: Unit type

EWW = WW HP / inversion on water

EWH = WW HP / inversion on refrigerant

EWL = Condenserless

4. Options

Features provided as standard

- 20mm evaporator insulation
- Electronic expansion valve
- Evaporator and Condenser Victaulic kit
- Set-point reset
- Demand limit
- Evaporator flow switch
- Hour run meter
- General fault contactor
- Master/Slave
- ModBus RTU MSTP
- Main switch interlock door

Options on demand

OPT03 – Partial Heat recovery.

OPT07 – HEAT PUMP VERSION WITH REVERSIBILITY ON WATER SIDE

OPT33 – 20mm condenser insulation.

OPT127 – High- and Low-pressure side manometers.

OPT91 – Double pressure relief valve with diverter.

OPT15 – Under / Over voltage control.

OPT17 – Capacitors for power factors correction

OPT95 – Circuit Breakers

OPT121 - Refrigerant leak detector

OPT188 – Heating only mode

OPT 75 – Rubber anti vibration mounts.

OPT 77 – Spring Anti vibration mounts

OPT 71 – Container kit

OPT 112 – Transport kit

5. Accessories

Manifold module



To simplify the connection between different modules Daikin offers a manifold kit allowing to connect more modules in parallel.

There are two sizes available: 3" and 5". The manifold size is selected according to the flow rate of the system.

The manifold can be provided to ease the installation but is not mandatory. Customer or installer may decide to provide the connections between the modules on their own; this is possible as long as IOM prescriptions are respected.

Single power supply

Is possible to have a single array (up to four modules) with a single power supply. As standard (no accessory) each module must be connected to a separate power supply.

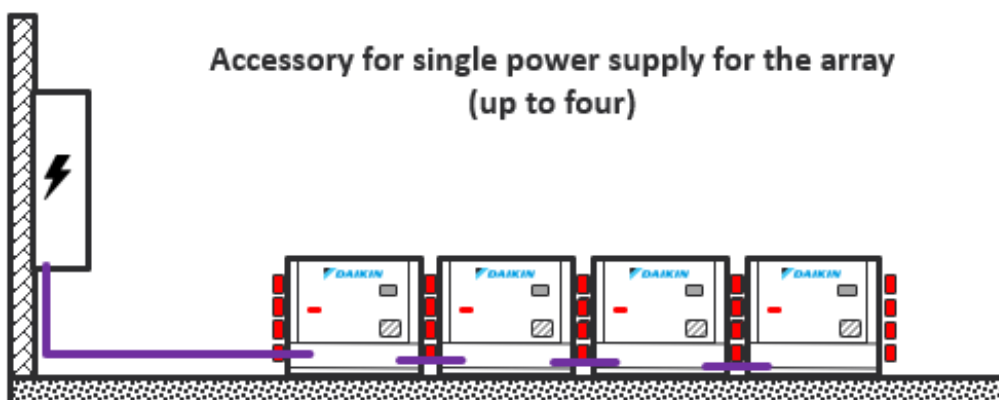
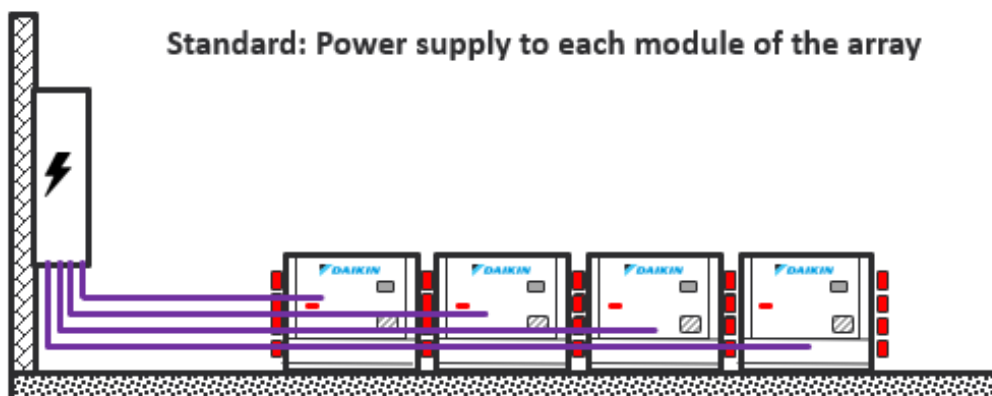

Stacked Installation, Side by Side installation

Select the accessory to stack modules (max two) or place side by side (max 4) to reduce footprint. Max size 8 modules (4+4 array) → 1280 kW (@ standard conditions).



Pump module

Pump modules are available as accessories to create a complete package. The pump modules are connected directly to the modules.

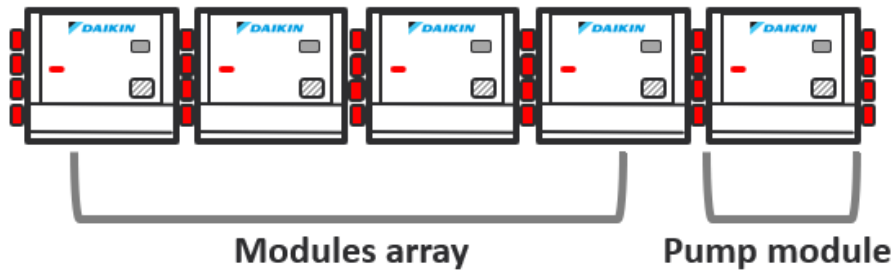

Additional module with pumps can be added. All pumps are inverter driven for full flexibility. The pump module includes an expansion tank (18 lt). Different sizes are available. Refer to CSS for the selection.



6. Technical data

EWWT Q- XS | Gold Efficiency, Standard Sound | 400 V / 3ph / 50 Hz

	Model		100	125	160
Cooling performances	Cooling Capacity ⁽¹⁾	kW	96,36	124,4	166,0
	Power input - cooling ⁽¹⁾	kW	20,99	27,95	34,44
	Cooling Efficiency – EER ⁽¹⁾	kW/kW	4,590	4,450	4,820
	Seasonal Energy Efficiency Ratio - SEER ⁽¹⁾⁽²⁾	kW/kW	6,400	6,540	6,490
	$\eta_{s,c}$ ⁽³⁾	%	253,0	258,6	256,6
	Seasonal Energy Performance Ratio - SEPR ⁽¹⁾⁽⁴⁾	kW/kW	7,990	8,360	8,720
	IPLV ⁽⁵⁾	kW/kW	7,150	7,120	7,410
	Evaporator flow rate ⁽¹⁾	l/s	4,60	5,930	7,920
	Evaporator pressure drop ⁽¹⁾⁽⁶⁾	kPa	19,35	20,00	22,1
	Condenser flow rate ⁽¹⁾	l/s	5,60	7,26	9,55
Condenser pressure drop ⁽¹⁾	kPa	27,81	28,00	33,60	
Heating performances	Heating Capacity ⁽⁷⁾	kW	110,2	142,8	186,7
	Power input - Heating ⁽⁷⁾	kW	26,11	34,49	42,53
	Heating Efficiency – COP ⁽⁷⁾	kW/kW	4,220	4,140	4,390
	Seasonal Coefficient Of Performance Low Temp.– SCOP LT ⁽⁸⁾	kW/kW	5,980	6,080	6,310
	Seasonal Coefficient Of Performance High Temp.– SCOP MT ⁽⁹⁾	kW/kW	4,720	4,810	4,940
	$\eta_{s,h}$ ⁽⁹⁾⁽¹⁰⁾	%	180,8	184,4	189,6
	Evaporator flow rate ⁽⁷⁾	l/s	6,73	8,67	11,5
	Evaporator pressure drop ⁽⁷⁾⁽⁶⁾	kPa	39,2	38,5	43,5
	Condenser flow rate ⁽⁷⁾	l/s	5,27	6,82	8,92
Condenser pressure drop ⁽⁷⁾	kPa	24,9	25,1	29,7	
General	Sound Power ⁽¹⁾⁽¹¹⁾ – Lw	dB(A)	81	84	86
	Number of circuits / Compressors	#	1 / 2	1 / 2	1 / 2
	Shipping weight ⁽¹²⁾	kg	419	469	531
	Operating weight ⁽¹²⁾	kg	439	491	561
	Running Current ⁽¹⁾⁽¹²⁾⁽¹³⁾	A	36,6	44,2	52,6
	Max Running Current ⁽¹²⁾⁽¹³⁾	A	62,0	80,0	97,0
	Max Current Wires Sizing ⁽¹²⁾⁽¹³⁾	A	68,0	88,0	107

i) The above data are referred to the unit without additional optional.

ii) The above data are referred the unit installed in compliancy with installation prescription.

iii) All the data are subject to change without notice. For updated information on project base refer to Chiller Selection Software and unit's certified drawing

- (1) Standard Rating Conditions for Water-to-Water chillers according to EN14511:2 Outdoor Heat exchanger inlet temperature 30°C, outlet 35°C; Indoor heat exchanger inlet temperature 12°C, outlet temperature 7°C. Fluid: water, Fouling factor = 0
- (2) Seasonal Energy Efficiency Ratio as defined in EN14825, part load condition in cooling for Water-to-Water units, fan coil application, variable outlet, fixed flow.
- (3) The seasonal space cooling energy efficiency $\eta_{s,c}$ is calculated as defined in Regulation (EU) 2016/2281 the seasonal energy efficiency ratio SEER divided by the conversion coefficient CC (2.5), corrected by contributions accounting for temperature control (0.08).
- (4) Seasonal Energy Performance Ratio as defined in EN14825, part load condition in cooling for Water-to-Water units, high temperature application.
- (5) Based on AHRI conditions
- (6) Fluid: water, not including filter pressure drop. The installation of the filter is mandatory.
- (7) Standard Rating Conditions for Water-to-Water heat pumps intermediate applications according to EN14511:2 Outdoor Heat exchanger inlet temperature 10°C, outlet 7°C; Indoor heat exchanger inlet temperature 40°C, outlet water temperature 45°C. Fluid: water, Fouling factor = 0
- (8) Seasonal Coefficient of performance as defined in EN14825, part load condition in heating for Water-to-Water units, Low temperature application, variable outlet, variable flow.
- (9) Seasonal Coefficient of performance as defined in EN14825, part load condition in heating for Water-to-Water units, medium temperature application, variable outlet, variable flow.
- (10) The seasonal space heating energy efficiency $\eta_{s,h}$ is calculated as defined in Regulation (EU) 2016/2281 the seasonal energy efficiency ratio SCOP divided by the conversion coefficient CC (2.5), corrected by contributions accounting for temperature control (0.08).
- (11) Sound power level measured in accordance with ISO9614, referred to unit operating at Standard Rating Conditions for Water-to-Water chillers according to EN14511:2 ref conditions (1)
- (12) This are intended as guideline only and referred for unit without options. Refer to dedicated wiring diagram, unit nameplate and dedicated drawing for specific values.
- (13) ±10% tolerance on Voltage, Voltage unbalance between phases must be within ± 3%.

Eurovent certified data

EWWT Q- XR | Gold Efficiency, Standard Sound | 400 V / 3ph / 50 Hz

Model		100	125	160	
Cooling performances	Cooling Capacity ⁽¹⁾	kW	96,36	124,4	166,0
	Power input - cooling ⁽¹⁾	kW	20,99	27,95	34,44
	Cooling Efficiency – EER ⁽¹⁾	kW/kW	4,590	4,450	4,820
	Seasonal Energy Efficiency Ratio - SEER ⁽¹⁾⁽²⁾	kW/kW	6,400	6,540	6,490
	$\eta_{s,c}$ ⁽³⁾	%	253,0	258,6	256,6
	Seasonal Energy Performance Ratio - SEPR ⁽¹⁾⁽⁴⁾	kW/kW	7,990	8,360	8,720
	IPLV ⁽⁵⁾	kW/kW	7,150	7,120	7,410
	Evaporator flow rate ⁽¹⁾	l/s	4,60	5,930	7,920
	Evaporator pressure drop ⁽¹⁾⁽⁶⁾	kPa	19,35	20,00	22,1
	Condenser flow rate ⁽¹⁾	l/s	5,60	7,26	9,55
Condenser pressure drop ⁽¹⁾	kPa	27,81	28,00	33,60	
Heating performances	Heating Capacity ⁽⁷⁾	kW	110,2	142,8	186,7
	Power input - Heating ⁽⁷⁾	kW	26,11	34,49	42,53
	Heating Efficiency – COP ⁽⁷⁾	kW/kW	4,220	4,140	4,390
	Seasonal Coefficient Of Performance Low Temp.– SCOP LT ⁽⁸⁾	kW/kW	5,980	6,080	6,310
	Seasonal Coefficient Of Performance High Temp.– SCOP HT ⁽⁹⁾	kW/kW	4,720	4,810	4,940
	$\eta_{s,h}$ ⁽⁹⁾⁽¹⁰⁾	%	180,8	184,4	189,6
	Evaporator flow rate ⁽⁷⁾	l/s	6,73	8,67	11,5
	Evaporator pressure drop ⁽⁷⁾⁽⁶⁾	kPa	39,2	38,5	43,5
	Condenser flow rate ⁽⁷⁾	l/s	5,27	6,82	8,92
	Condenser pressure drop ⁽⁷⁾	kPa	24,9	25,1	29,7
General	Sound Power ⁽¹⁾⁽¹¹⁾ – Lw	dB(A)	75	78	80
	Number of circuits / Compressors	#	1 / 2	1 / 2	1 / 2
	Shipping weight ⁽¹²⁾	kg	470	520	582
	Operating weight ⁽¹²⁾	kg	490	542	612
	Running Current ⁽¹⁾⁽¹²⁾⁽¹³⁾	A	36,6	44,2	52,6
	Max Running Current ⁽¹²⁾⁽¹³⁾	A	62,0	80,0	97,0
	Max Current Wires Sizing ⁽¹²⁾⁽¹³⁾	A	68,0	88,0	107

i) The above data are referred to the unit without additional optional.

ii) The above data are referred the unit installed in compliancy with installation prescription.

iii) All the data are subject to change without notice. For updated information on project base refer to Chiller Selection Software and unit's certified drawing

- (1) Standard Rating Conditions for Water-to-Water chillers according to EN14511:2 Outdoor Heat exchanger inlet temperature 30°C, outlet 35°C; Indoor heat exchanger inlet temperature 12°C, outlet temperature 7°C. Fluid: water, Fouling factor = 0
- (2) Seasonal Energy Efficiency Ratio as defined in EN14825, part load condition in cooling for Water-to-Water units, fan coil application, variable outlet, fixed flow.
- (3) The seasonal space cooling energy efficiency $\eta_{s,c}$ is calculated as defined in Regulation (EU) 2016/2281 the seasonal energy efficiency ratio SEER divided by the conversion coefficient CC (2.5), corrected by contributions accounting for temperature control (0.08).
- (4) Seasonal Energy Performance Ratio as defined in EN14825, part load condition in cooling for Water-to-Water units, high temperature application.
- (5) Based on AHRI conditions
- (6) Fluid: water, not including filter pressure drop. The installation of the filter is mandatory.
- (7) Standard Rating Conditions for Water-to-Water heat pumps intermediate applications according to EN14511:2 Outdoor Heat exchanger inlet temperature 10°C, outlet 7°C; Indoor heat exchanger inlet temperature 40°C, outlet water temperature 45°C. Fluid: water, Fouling factor = 0
- (8) Seasonal Coefficient of performance as defined in EN14825, part load condition in heating for Water-to-Water units, Low temperature application, variable outlet, variable flow.
- (9) Seasonal Coefficient of performance as defined in EN14825, part load condition in heating for Water-to-Water units, medium temperature application, variable outlet, variable flow.
- (10) The seasonal space cooling energy efficiency $\eta_{s,c}$ is calculated as defined in Regulation (EU) 2016/2281 the seasonal energy efficiency ratio SCOP divided by the conversion coefficient CC (2.5), corrected by contributions accounting for temperature control (0.08).
- (11) Sound power level measured in accordance with ISO9614, referred to unit operating at Standard Rating Conditions for Water-to-Water chillers according to EN14511:2 ref conditions (1)
- (12) This are intended as guideline only and referred for unit without options. Refer to dedicated wiring diagram, unit nameplate and dedicated drawing for specific values.
- (13) ±10% tolerance on Voltage, Voltage unbalance between phases must be within ± 3%.

Eurovent certified data

EWHT Q- XS | Gold Efficiency, Standard Sound | 400 V / 3ph / 50 Hz

	Model		100
Cooling performances	Cooling Capacity ⁽¹⁾	kW	91,68
	Power input - cooling ⁽¹⁾	kW	21,22
	Cooling Efficiency – EER ⁽¹⁾	kW/kW	4,320
	Seasonal Energy Efficiency Ratio - SEER ⁽¹⁾⁽²⁾	kW/kW	5,980
	$\eta_{s,c}$ ⁽³⁾	%	236,2
	Seasonal Energy Performance Ratio - SEPR ⁽¹⁾⁽⁴⁾	kW/kW	7,470
	IPLV ⁽⁵⁾	kW/kW	6,660
	Evaporator flow rate ⁽¹⁾	l/s	4,37
	Evaporator pressure drop ⁽¹⁾⁽⁶⁾	kPa	17,70
	Condenser flow rate ⁽¹⁾	l/s	5,39
Condenser pressure drop ⁽¹⁾	kPa	25,90	
Heating performances	Heating Capacity ⁽⁷⁾	kW	106,0
	Power input - Heating ⁽⁷⁾	kW	26,30
	Heating Efficiency – COP ⁽⁷⁾	kW/kW	4,030
	Seasonal Coefficient Of Performance Low Temp.– SCOP LT ⁽⁸⁾	kW/kW	5,780
	Seasonal Coefficient Of Performance High Temp.– SCOP HT ⁽⁹⁾	kW/kW	4,550
	$\eta_{s,h}$ ⁽⁹⁾⁽¹⁰⁾	%	174,0
	Evaporator flow rate ⁽⁷⁾	l/s	6,38
	Evaporator pressure drop ⁽⁷⁾⁽⁶⁾	kPa	35,40
	Condenser flow rate ⁽⁷⁾	l/s	5,07
Condenser pressure drop ⁽⁷⁾	kPa	23,20	
General	Sound Power ⁽¹⁾⁽¹¹⁾ – Lw	dB(A)	81
	Number of circuits / Compressors	#	1 / 2
	Shipping weight ⁽¹²⁾	kg	431
	Operating weight ⁽¹²⁾	kg	451
	Running Current ⁽¹⁾⁽¹²⁾⁽¹³⁾	A	36,9
	Max Running Current ⁽¹²⁾⁽¹³⁾	A	62,0
	Max Current Wires Sizing ⁽¹²⁾⁽¹³⁾	A	68,0

i) The above data are referred to the unit without additional optional.

ii) The above data are referred the unit installed in compliancy with installation prescription.

iii) All the data are subject to change without notice. For updated information on project base refer to Chiller Selection Software and unit's certified drawing

- (1) Standard Rating Conditions for Water-to-Water chillers according to EN14511:2 Outdoor Heat exchanger inlet temperature 30°C, outlet 35°C; Indoor heat exchanger inlet temperature 12°C, outlet temperature 7°C. Fluid: water, Fouling factor = 0
- (2) Seasonal Energy Efficiency Ratio as defined in EN14825, part load condition in cooling for Water-to-Water units, fan coil application, variable outlet, fixed flow.
- (3) The seasonal space cooling energy efficiency $\eta_{s,c}$ is calculated as defined in Regulation (EU) 2016/2281 the seasonal energy efficiency ratio SEER divided by the conversion coefficient CC (2.5), corrected by contributions accounting for temperature control (0.08).
- (4) Seasonal Energy Performance Ratio as defined in EN14825, part load condition in cooling for Water-to-Water units, high temperature application.
- (5) Based on AHRI conditions
- (6) Fluid: water, not including filter pressure drop. The installation of the filter is mandatory.
- (7) Standard Rating Conditions for Water-to-Water heat pumps intermediate applications according to EN14511:2 Outdoor Heat exchanger inlet temperature 10°C, outlet 7°C; Indoor heat exchanger inlet temperature 40°C, outlet water temperature 45°C. Fluid: water, Fouling factor = 0
- (8) Seasonal Coefficient of performance as defined in EN14825, part load condition in heating for Water-to-Water units, Low temperature application, variable outlet, variable flow.
- (9) Seasonal Coefficient of performance as defined in EN14825, part load condition in heating for Water-to-Water units, medium temperature application, variable outlet, variable flow.
- (10) The seasonal space cooling energy efficiency $\eta_{s,c}$ is calculated as defined in Regulation (EU) 2016/2281 the seasonal energy efficiency ratio SCOP divided by the conversion coefficient CC (2.5), corrected by contributions accounting for temperature control (0.08).
- (11) Sound power level measured in accordance with ISO9614, referred to unit operating at Standard Rating Conditions for Water-to-Water chillers according to EN14511:2 ref conditions (1)
- (12) This are intended as guideline only and referred for unit without options. Refer to dedicated wiring diagram, unit nameplate and dedicated drawing for specific values.
- (13) ±10% tolerance on Voltage, Voltage unbalance between phases must be within ± 3%.

Eurovent certified data

EWHT Q- XR | Gold Efficiency, Standard Sound | 400 V / 3ph / 50 Hz

Model			100
Cooling performances	Cooling Capacity ⁽¹⁾	kW	91,68
	Power input - cooling ⁽¹⁾	kW	21,22
	Cooling Efficiency – EER ⁽¹⁾	kW/kW	4,320
	Seasonal Energy Efficiency Ratio - SEER ⁽¹⁾⁽²⁾	kW/kW	5,980
	$\eta_{s,c}$ ⁽³⁾	%	236,2
	Seasonal Energy Performance Ratio - SEPR ⁽¹⁾⁽⁴⁾	kW/kW	7,470
	IPLV ⁽⁵⁾	kW/kW	6,660
	Evaporator flow rate ⁽¹⁾	l/s	4,37
	Evaporator pressure drop ⁽¹⁾⁽⁶⁾	kPa	17,70
	Condenser flow rate ⁽¹⁾	l/s	5,39
	Condenser pressure drop ⁽¹⁾	kPa	25,90
Heating performances	Heating Capacity ⁽⁷⁾	kW	106,0
	Power input - Heating ⁽⁷⁾	kW	26,30
	Heating Efficiency – COP ⁽⁷⁾	kW/kW	4,030
	Seasonal Coefficient Of Performance Low Temp.– SCOP LT ⁽⁸⁾	kW/kW	5,780
	Seasonal Coefficient Of Performance High Temp.– SCOP HT ⁽⁹⁾	kW/kW	4,550
	$\eta_{s,h}$ ⁽⁹⁾⁽¹⁰⁾	%	174,0
	Evaporator flow rate ⁽⁷⁾	l/s	6,38
	Evaporator pressure drop ⁽⁷⁾⁽⁶⁾	kPa	35,40
	Condenser flow rate ⁽⁷⁾	l/s	5,07
	Condenser pressure drop ⁽⁷⁾	kPa	23,20
General	Sound Power ⁽¹⁾⁽¹¹⁾ – Lw	dB(A)	75
	Number of circuits / Compressors	#	1 / 2
	Shipping weight ⁽¹²⁾	kg	482
	Operating weight ⁽¹²⁾	kg	502
	Running Current ⁽¹⁾⁽¹²⁾⁽¹³⁾	A	36,9
	Max Running Current ⁽¹²⁾⁽¹³⁾	A	62,0
	Max Current Wires Sizing ⁽¹²⁾⁽¹³⁾	A	68,0

i) The above data are referred to the unit without additional optional.

ii) The above data are referred the unit installed in compliancy with installation prescription.

iii) All the data are subject to change without notice. For updated information on project base refer to Chiller Selection Software and unit's certified drawing

- (1) Standard Rating Conditions for Water-to-Water chillers according to EN14511:2 Outdoor Heat exchanger inlet temperature 30°C, outlet 35°C; Indoor heat exchanger inlet temperature 12°C, outlet temperature 7°C. Fluid: water, Fouling factor = 0
- (2) Seasonal Energy Efficiency Ratio as defined in EN14825, part load condition in cooling for Water-to-Water units, fan coil application, variable outlet, fixed flow.
- (3) The seasonal space cooling energy efficiency $\eta_{s,c}$ is calculated as defined in Regulation (EU) 2016/2281 the seasonal energy efficiency ratio SEER divided by the conversion coefficient CC (2.5), corrected by contributions accounting for temperature control (0.08).
- (4) Seasonal Energy Performance Ratio as defined in EN14825, part load condition in cooling for Water-to-Water units, high temperature application.
- (5) Based on AHRI conditions
- (6) Fluid: water, not including filter pressure drop. The installation of the filter is mandatory.
- (7) Standard Rating Conditions for Water-to-Water heat pumps intermediate applications according to EN14511:2 Outdoor Heat exchanger inlet temperature 10°C, outlet 7°C; Indoor heat exchanger inlet temperature 40°C, outlet water temperature 45°C. Fluid: water, Fouling factor = 0
- (8) Seasonal Coefficient of performance as defined in EN14825, part load condition in heating for Water-to-Water units, Low temperature application, variable outlet, variable flow.
- (9) Seasonal Coefficient of performance as defined in EN14825, part load condition in heating for Water-to-Water units, medium temperature application, variable outlet, variable flow.
- (10) The seasonal space cooling energy efficiency $\eta_{s,c}$ is calculated as defined in Regulation (EU) 2016/2281 the seasonal energy efficiency ratio SCOP divided by the conversion coefficient CC (2.5), corrected by contributions accounting for temperature control (0.08).
- (11) Sound power level measured in accordance with ISO9614, referred to unit operating at Standard Rating Conditions for Water-to-Water chillers according to EN14511:2 ref conditions (1)
- (12) This are intended as guideline only and referred for unit without options. Refer to dedicated wiring diagram, unit nameplate and dedicated drawing for specific values.
- (13) ±10% tolerance on Voltage, Voltage unbalance between phases must be within ± 3%.

Eurovent certified data

EWLT Q- XS | Gold Efficiency, Reduced Sound | 400 V / 3ph / 50 Hz

Model			100	125	160
Cooling performances	Cooling Capacity ⁽¹⁾	kW	90,2	116,9	155,0
	Power input - cooling ⁽¹⁾	kW	23,67	31,10	38,55
	Cooling Efficiency – EER ⁽¹⁾	kW/kW	3,81	3,76	4,02
	Evaporator flow rate ⁽¹⁾	l/s	4,30	5,58	7,39
	Evaporator pressure drop ⁽¹⁾⁽²⁾	kPa	17,16	17,93	19,55
General	Sound Power ⁽¹⁾⁽³⁾ – Lw	dB(A)	81	84	86
	Number of circuits / Compressors	#	1/2	1/2	1/2
	Shipping weight ⁽⁴⁾	kg	372	417	467
	Operating weight ⁽⁴⁾	kg	382	428	482
	Running Current ⁽¹⁾⁽⁴⁾⁽⁵⁾	A	42,1	50,0	60,7
	Max Running Current ⁽⁴⁾⁽⁵⁾	A	62,0	80,0	97,0
	Max Current Wires Sizing ⁽⁴⁾⁽⁵⁾	A	68,0	88,0	107

i) The above data are referred to the unit without additional optional.

ii) The above data are referred the unit installed in compliancy with installation prescription.

iii) All the data are subject to change without notice. For updated information on project base refer to Chiller Selection Software and unit’s certified drawing

- (1) Standard Rating Conditions for DX to Water chillers: Condensing temperature = 45°C; Indoor heat exchanger inlet water temperature 12°C, outlet water temperature 7°C. Fluid: water, Fouling factor = 0
- (2) Fluid: water, not including filter pressure drop. The installation of the filter is mandatory.
- (3) Sound power level measured in accordance with ISO9614, referred to unit operating at Standard Rating Conditions for Air to water chillers according to EN14511:2 Outdoor Heat exchanger inlet dry bulb temperature 35°; Indoor heat exchanger inlet water temperature 12°C, outlet water temperature 7°C
- (4) This are intended as guideline only and referred for unit without options. Refer to dedicated wiring diagram, unit nameplate and dedicated drawing for specific values. Value intended as guideline. Refer to unit nameplate for specific value.
- (5) ±10% tolerance on Voltage, Voltage unbalance between phases must be within ± 3%.

EWLT Q- XR Gold Efficiency, Reduced Sound 400 V / 3ph / 50 Hz					
	Model		100	125	160
Cooling performances	Cooling Capacity ⁽¹⁾	kW	90,20	116,9	155,0
	Power input - cooling ⁽¹⁾	kW	23,67	31,10	38,55
	Cooling Efficiency – EER ⁽¹⁾	kW/kW	3,81	3,76	4,02
	Evaporator flow rate ⁽¹⁾	l/s	4,30	5,58	7,39
	Evaporator pressure drop ⁽¹⁾⁽²⁾	kPa	17,16	17,93	19,55
General	Sound Power ⁽¹⁾⁽³⁾ – Lw	dB(A)	75	78	80
	Number of circuits / Compressors	#	1/2	1/2	1/2
	Shipping weight ⁽⁴⁾	kg	423	468	518
	Operating weight ⁽⁴⁾	kg	433	479	533
	Running Current ⁽¹⁾⁽⁴⁾⁽⁵⁾	A	42,1	50,0	60,7
	Max Running Current ⁽⁴⁾⁽⁵⁾	A	62,0	80,0	97,0
	Max Current Wires Sizing ⁽⁴⁾⁽⁵⁾	A	68,0	88,0	107

i) The above data are referred to the unit without additional optional.
 ii) The above data are referred the unit installed in compliancy with installation prescription.
 iii) All the data are subject to change without notice. For updated information on project base refer to Chiller Selection Software and unit’s certified drawing

(1) Standard Rating Conditions for DX to Water chillers: Condensing temperature = 45°C; Indoor heat exchanger inlet water temperature 12°C, outlet water temperature 7°C. Fluid: water, Fouling factor = 0
 (2) Fluid: water, not including filter pressure drop. The installation of the filter is mandatory.
 (3) Sound power level measured in accordance with ISO9614, referred to unit operating at Standard Rating Conditions for Air to water chillers according to EN14511:2 Outdoor Heat exchanger inlet dry bulb temperature 35°; Indoor heat exchanger inlet water temperature 12°C, outlet water temperature 7°C
 (4) This are intended as guideline only and referred for unit without options. Refer to dedicated wiring diagram, unit nameplate and dedicated drawing for specific values. Value intended as guideline. Refer to unit nameplate for specific value.
 (5) ±10% tolerance on Voltage, Voltage unbalance between phases must be within ± 3%.

7. Sound data

7.1 Gold Efficiency – Standard Sound

EWWT Q- XS Gold Efficiency, Standard Sound										
Model	Sound pressure level @ 1 m from the unit (rif. 2×10^{-5} Pa)								Sound pressure Lp @ 1 m	Sound power Lw
	63 Hz	125 Hz	250 Hz	500 Hz	1000 Hz	2000 Hz	4000 Hz	8000 Hz		
	dB(A)								dB(A)	dB(A)
100	64,8	71,5	72,3	71,9	73,5	77,9	69,7	60,4	65,4	81,0
125	68,0	74,7	75,5	75,1	76,7	81,1	72,9	63,6	68,6	84,2
160	69,8	76,5	77,3	76,9	78,5	82,9	74,7	65,4	70,4	86,0
EWHT Q- XS Gold Efficiency, Standard Sound										
100	64,8	71,5	72,3	71,9	73,5	77,9	69,7	60,4	65,4	81,0
EWLT Q- XS Gold Efficiency, Standard Sound										
100	64,8	71,5	72,3	71,9	73,5	77,9	69,7	60,4	65,4	81,0
125	68,0	74,7	75,5	75,1	76,7	81,1	72,9	63,6	68,6	84,2
160	69,8	76,5	77,3	76,9	78,5	82,9	74,7	65,4	70,4	86,0

i) The above data are referred to the unit without additional optional.
ii) The above data are referred the unit installed in compliancy with installation prescription.
iii) All the data are subject to change without notice. For updated information on project base refer to Chiller Selection Software and unit's certified drawing

Standard Rating Conditions for Water-to-Water chillers according to EN14511:2 Outdoor Heat exchanger inlet temperature 30°C, outlet 35°C; Indoor heat exchanger inlet temperature 12°C, outlet temperature 7°C. Fluid: water, fouling factor = 0
Sound Power levels are measured in accordance with ISO 9614
Sound Pressure at levels 1 meter are measured in accordance with ISO 3744

NOTE: The sound data in the Octave band spectrum is based on calculation, thus intended as general guideline, and not considered binding. All data are subject to change without notice. For updated information on project base refer to specific selections.

All above data are referred to base unit without options. Options may affect sound data, contact factory Daikin representative for additional info.

EWWT Q- XS | Gold Efficiency, Standard Sound

Model	Sound Power Lw [dB(A)]	Sound pressure - Lp [dB(A)] at									
		1 m	2 m	3 m	4 m	5 m	6 m	7m	8 m	9 m	10 m
100	81,0	65,4	61,4	58,7	56,7	55,0	53,6	52,4	51,4	50,4	49,6
125	84,2	68,6	64,6	61,9	59,9	58,2	56,8	55,6	54,6	53,6	52,8
160	86,0	70,4	66,4	63,7	61,7	60,0	58,6	57,4	56,4	55,4	54,6

EWHT Q- XS | Gold Efficiency, Standard Sound

100	81,0	65,4	61,4	58,7	56,7	55,0	53,6	52,4	51,4	50,4	49,6
-----	------	------	------	------	------	------	------	------	------	------	------

EWLT Q- XS | Gold Efficiency, Standard Sound

100	81,0	65,4	61,4	58,7	56,7	55,0	53,6	52,4	51,4	50,4	49,6
125	84,2	68,6	64,6	61,9	59,9	58,2	56,8	55,6	54,6	53,6	52,8
160	86,0	70,4	66,4	63,7	61,7	60,0	58,6	57,4	56,4	55,4	54,6

- i) The above data are referred to the unit without additional optional.
- ii) The above data are referred the unit installed in compliancy with installation prescription.
- iii) All the data are subject to change without notice. For updated information on project base refer to Chiller Selection Software and unit's certified drawing

Standard Rating Conditions for Water-to-Water chillers according to EN14511:2 Outdoor Heat exchanger inlet temperature 30°C, outlet 35°C; Indoor heat exchanger inlet temperature 12°C, outlet temperature 7°C. Fluid: water, fouling factor = 0
 Sound Power levels are measured in accordance with ISO 9614
 Sound Pressure levels at 1 meter are measured in accordance with ISO 3744

Sound pressure at distance > 1 meter is calculated from the sound power as follows:

$$L_p = L_w - 10 \times \text{Log}_{10}(A_d)$$

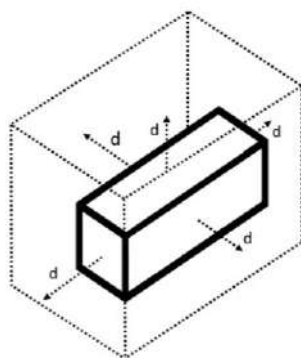

where Ad being the surface around the chiller calculated at the specific distance d

7.2 Gold Efficiency – Reduced Sound

EWWT Q- XR Gold Efficiency, Reduced Sound										
Model	Sound pressure level @ 1 m from the unit (rif. 2×10^{-5} Pa)								Sound pressure Lp @ 1 m	Sound power Lw
	63 Hz	125 Hz	250 Hz	500 Hz	1000 Hz	2000 Hz	4000 Hz	8000 Hz		
	dB(A)								dB(A)	dB(A)
100	58,8	65,5	66,3	65,9	67,5	71,9	63,7	54,4	59,4	75,0
125	62,0	68,7	69,5	69,1	70,7	75,1	66,9	57,6	62,6	78,2
160	63,8	70,5	71,3	70,9	72,5	76,9	68,7	59,4	64,4	80,0
EWHT Q- XR Gold Efficiency, Reduced Sound										
100	58,8	65,5	66,3	65,9	67,5	71,9	63,7	54,4	59,4	75,0
EWLT Q- XR Gold Efficiency, Reduced Sound										
100	58,8	65,5	66,3	65,9	67,5	71,9	63,7	54,4	59,4	75,0
125	62,0	68,7	69,5	69,1	70,7	75,1	66,9	57,6	62,6	78,2
160	63,8	70,5	71,3	70,9	72,5	76,9	68,7	59,4	64,4	80,0

i) The above data are referred to the unit without additional optional.
ii) The above data are referred the unit installed in compliancy with installation prescription.
iii) All the data are subject to change without notice. For updated information on project base refer to Chiller Selection Software and unit's certified drawing

Standard Rating Conditions for Water-to-Water chillers according to EN14511:2 Outdoor Heat exchanger inlet temperature 30°C, outlet 35°C; Indoor heat exchanger inlet temperature 12°C, outlet temperature 7°C. Fluid: water, fouling factor = 0 Sound Power levels are measured in accordance with ISO 9614
Sound Pressure at levels 1 meter are measured in accordance with ISO 3744

NOTE: The sound data in the Octave band spectrum is based on calculation, thus intended as general guideline, and not considered binding. All data are subject to change without notice. For updated information on project base refer to specific selections.

All above data are referred to base unit without options. Options may affect sound data, contact factory Daikin representative for additional info.

EWWT Q- XR | Gold Efficiency, Reduced Sound

Model	Sound Power Lw [dB(A)]	Sound pressure - Lp [dB(A)] at									
		1 m	2 m	3 m	4 m	5 m	6 m	7m	8 m	9 m	10 m
100	75	59,4	55,4	52,7	50,7	49,0	47,6	46,4	45,4	44,4	43,6
125	78,2	62,6	58,6	55,9	53,9	52,2	50,8	49,6	48,6	47,6	46,8
160	80	64,4	60,4	57,7	55,7	54,0	52,6	51,4	50,4	49,4	48,6

EWHT Q- XR | Gold Efficiency, Reduced Sound

100	75	59,4	55,4	52,7	50,7	49,0	47,6	46,4	45,4	44,4	43,6
-----	----	------	------	------	------	------	------	------	------	------	------

EWLT Q- XR | Gold Efficiency, Reduced Sound

100	75	59,4	55,4	52,7	50,7	49,0	47,6	46,4	45,4	44,4	43,6
125	78,2	62,6	58,6	55,9	53,9	52,2	50,8	49,6	48,6	47,6	46,8
160	80	64,4	60,4	57,7	55,7	54,0	52,6	51,4	50,4	49,4	48,6

- i) The above data are referred to the unit without additional optional.
- ii) The above data are referred the unit installed in compliancy with installation prescription.
- iii) All the data are subject to change without notice. For updated information on project base refer to Chiller Selection Software and unit's certified drawing

Sound Performance referred to Standard Rating Conditions for Water-to-Water chillers according to EN14511:2 Outdoor Heat exchanger inlet temperature 30°C, outlet 35°C; Indoor heat exchanger inlet temperature 12°C, outlet temperature 7°C. Fluid: water, Fouling factor = 0

Sound Power levels are measured in accordance with ISO 9614

Sound Pressure levels at 1 meter are measured in accordance with ISO 3744

Sound pressure at distance > 1 meter is calculated from the sound power as follows:

$$L_p = L_w - 10 \times \log_{10}(A_d)$$

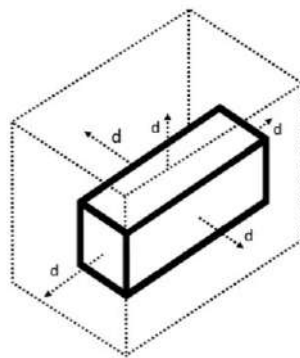

where Ad being the surface around the chiller calculated at the specific distance d

8. Electrical data

EWWT Q- XS/XR Gold Efficiency, Standard & Reduced Sound					
Models	Auxiliary circuit	FLA	Max Inrush Current	Entry cross section cable	SCC l _w 1 Sec.
	[A]	[A]	[A]	q.ty x mm ²	kA eff
EWWT100Q-XSA1	1,25	62,0	221	3x70mm ² + PE 35mm ²	2,50
EWWT125Q-XSA1	1,25	80,0	345	3x70mm ² + PE 35mm ²	2,50
EWWT160Q-XSA1	1,25	97,0	363	3x70mm ² + PE 35mm ²	2,50
EWHT100Q-XSA1	1,25	62,0	221	3x70mm ² + PE 35mm ²	2,50
EWLT100Q-XSA1	1,25	62,0	221	3x70mm ² + PE 35mm ²	2,50
EWLT125Q-XSA1	1,25	80,0	345	3x70mm ² + PE 35mm ²	2,50
EWLT160Q-XSA1	1,25	97,0	363	3x70mm ² + PE 35mm ²	2,50
EWWT100Q-XRA1	1,25	62,0	221	3x70mm ² + PE 35mm ²	2,50
EWWT125Q-XRA1	1,25	80,0	345	3x70mm ² + PE 35mm ²	2,50
EWWT160Q-XRA1	1,25	97,0	363	3x70mm ² + PE 35mm ²	2,50
EWHT100Q-XRA1	1,25	62,0	221	3x70mm ² + PE 35mm ²	2,50
EWLT100Q-XRA1	1,25	62,0	221	3x70mm ² + PE 35mm ²	2,50
EWLT125Q-XRA1	1,25	80,0	345	3x70mm ² + PE 35mm ²	2,50
EWLT160Q-XRA1	1,25	97,0	363	3x70mm ² + PE 35mm ²	2,50



The above data are referred to the unit without additional optional.
All the data are intended as guideline and are subject to change without notice. For updated information on project base refer to dedicated wiring diagram

9. System data

The base modules can be combined to meet required capacity and installed to optimize footprint. The below data are calculated at Standard Rating Conditions for Water-to-Water units according to EN14511:2.

9.1 Two modules

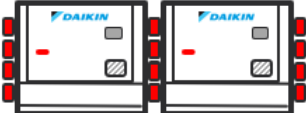
Model (EWWT Q-X-A1)		100 +	100 +	125 +	125 +	160 +
		100	125	125	160	160
Cooling Capacity	kW	192,8	220,7	248,7	289,3	331,5
Power Input – Cooling	kW	42,11	49,10	56,11	61,73	68,94
Cooling Efficiency – EER	kW/kW	4,578	4,495	4,432	4,686	4,809
Heating Capacity	kW	220,3	252,5	285,6	328,6	373,4
Power Input – Heating	kW	52,20	62,19	69,04	76,62	85,02
Heating Efficiency – COP	kW/kW	4,221	4,060	4,136	4,289	4,392
Standard Sound Version – Lw	dB(A)	84	86	87	88	89
Reduced Sound Version – Lw	dB(A)	78	80	81	82	83
Number of circuits / Compressors	#	2 / 4	2 / 4	2 / 4	2 / 4	2 / 4
Running Current	A	73,2	80,8	88,5	96,0	105,3
Max Running Current	A	124	142	160	177	194
Max Current Wires Sizing	A	136	156	176	194	213
Max Inrush Current	A	280	404	422	439	457
Standard Sound Version – Operating Weight	kg	878	930	982	1052	1122
Reduced Sound Version – Operating Weight	kg	978	1031	1084	1154	1223

Layout	Dimensions		
<p>Array of 2 w/manifold</p> 	Length	mm	1300
	Width	mm	2400
	Height	mm	1000
<p>stacked w/o manifold</p> 	Length	mm	1300
	Width	mm	1200
	Height	mm	2000

9.2 Three modules

		100	100	125	125	125	160
		+	+	+	+	+	+
Model (EWWT Q-X-A1)		100	125	125	125	160	160
		+	+	+	+	+	+
		125	125	125	160	160	160
Cooling Capacity	kW	317,1	345,1	373,0	413,3	454,8	497,3
Power Input – Cooling	kW	70,15	77,16	84,17	89,11	96,14	103,4
Cooling Efficiency – EER	kW/kW	4,520	4,472	4,432	4,638	4,73	4,809
Heating Capacity	kW	362,3	395,2	428,3	471,9	515,7	560,1
Power Input – Heating	kW	88,98	97,60	103,6	114,7	123,2	127,5
Heating Efficiency – COP	kW/kW	4,072	4,049	4,136	4,114	4,187	4,392
Standard Sound Version – Lw	dB(A)	87	88	89	90	90	91
Reduced Sound Version – Lw	dB(A)	81	82	83	84	84	85
Number of circuits / Compressors	#	3/6	3/6	3/6	3/6	3/6	3/6
Running Current	A	117	125	133	140	149	158
Max Running Current	A	204	222	240	257	274	291
Max Current Wires Sizing	A	224	244	264	282	301	320
Max Inrush Current	A	465	482	500	518	535	553
Standard Sound Version – Operating Weight	kg	1369	1421	1473	1543	1613	1683
Reduced Sound Version – Operating Weight	kg	1520	1573	1626	1696	1766	1835

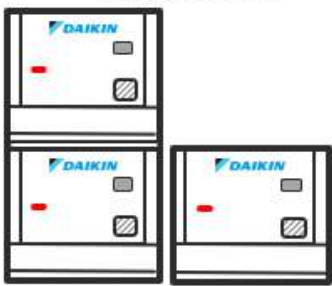
Layout	Dimensions		
<p>Array of 3 w/manifold</p> 	Length	mm	1300
	Width	mm	3600
	Height	mm	1000
<p>stacked w/o manifold</p> 	Length	mm	1300
	Width	mm	2400
	Height	mm	2000

9.3 Four modules

Model (EWWT Q-X-A1)		125	125	125	125	160
		+	+	+	+	+
		125	125	125	160	160
		+	+	+	+	+
		125	125	160	160	160
		+	+	+	+	+
		125	160	160	160	160
Cooling Capacity	kW	497,4	537,2	578,5	620,1	663,1
Power Input – Cooling	kW	112,2	116,5	123,5	130,4	137,9
Cooling Efficiency – EER	kW/kW	4,432	4,613	4,686	4,754	4,809
Heating Capacity	kW	571,1	614,6	658,4	702,2	746,8
Power Input – Heating	kW	138,1	150,1	158,6	167,1	170
Heating Efficiency – COP	kW/kW	4,136	4,094	4,151	4,203	4,392
Standard Sound Version – Lw	dB(A)	90	91	91	92	92
Reduced Sound Version – Lw	dB(A)	84	85	85	86	86
Number of circuits / Compressors	#	4 / 8	4 / 8	4 / 8	4 / 8	4 / 8
Running Current	A	177	183	192	201	211
Max Running Current	A	320	337	354	371	388
Max Current Wires Sizing	A	352	370	389	408	426
Max Inrush Current	A	578	596	614	631	649
Standard Sound Version – Operating Weight	kg	1964	2034	2104	2174	2244
Reduced Sound Version – Operating Weight	kg	2169	2238	2308	2377	2447

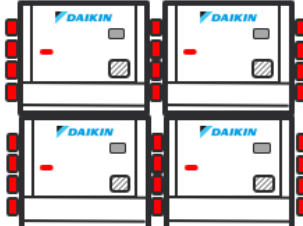
Layout	Dimensions		
<p>Array of 4 w/manifold</p> 	Length	mm	1300
	Width	mm	4800
	Height	mm	1000
<p>Array of (2 + 2) stacked w/manifold</p> 	Length	mm	1300
	Width	mm	2400
	Height	mm	2000

Larger systems can be created combining more arrays. The connections between the arrays must be provided on site.

9.4 Five modules

<p style="text-align: center;">Array of (2 + 3) stacked w/manifold</p> 	Length	mm	1300
	Width	mm	3600
	Height	mm	2000

9.5 Six modules

<p style="text-align: center;">Array of (3 + 3) stacked w/manifold</p> 	Length	mm	1300
	Width	mm	3600
	Height	mm	2000

9.6 Seven modules

<p style="text-align: center;">Array of (4 + 3) stacked w/manifold</p> 	Length	mm	1300
	Width	mm	4800
	Height	mm	2000

9.7 Eight modules

<p style="text-align: center;">Array of (4 + 4) stacked w/manifold</p> 	Length	mm	1300
	Width	mm	4800
	Height	mm	2000

10. Operating Limits

At Evaporator – Brazed Plate Heat Exchanger	Unit configuration	Fluid	Min [°C]	Max [°C]
Leaving water temperature range	Standard unit	Water	4	30
		Glycol Mix	-15	4
Entering water temperature range	Standard unit	Water	4	38
		Glycol Mix	-12	4
Entering water temperature range at start up	Standard unit	Water	4	38
		Glycol Mix	-12	4
Water Temperature difference across evaporator Entering - Leaving	Standard unit	Water	3	8
		Glycol Mix	3	8

For operation below 4°C leaving from evaporator the use of glycol mixture is mandatory.

The values above are intended as guidelines, refer to unit selection on project base for actual values.

At Condenser – Brazed Plate Heat Exchanger	Unit configuration	Fluid	Min [°C]	Max [°C]
Leaving water temperature range	Standard unit	Water	20	60
Entering water temperature range	Standard unit	Water	12	57
Entering water temperature range at start up	Standard unit	Water	12	57
Water Temperature difference across condenser Entering - Leaving	Standard unit	Water	3	8

Transportation and Storage temperature	Min [°C]	Max [°C]
	-30	60

At Partial Heat Recovery – BPHE	Unit configuration	Fluid	Min [°C]	Max [°C]
Leaving temperature range	With PHR	Water	33	60
Entering temperature range			30	57
Entering temperature range at start up			20	57

The values above are intended as guidelines, refer to unit selection on project base for actual values.

Max Operating Pressure on water side	Heat Exchanger	Bar
	Evaporator	20
	STD Unit with Flow Switch - Evaporator	10
	Unit with Manifold	10
	Partial Heat recovery	20

All above values are intended as guidelines which may change according to specific unit configurations.

Minimum flow rate in variable flow applications	Unit size		
	100	125	160
Heat Exchanger	2,83	3,61	4,64
Evaporator	2,83	3,61	4,64
Condenser	2,83	3,61	4,64
Partial Heat recovery	0,5	0,65	0,8

All above values are intended as guidelines which may change according to specific unit configurations.

NOTES

- All data are referred to installation of the unit at sea level. For information on operation of the unit please refer to Chiller Selection Software.
- For installation where ambient can reach temperature below +4°C, freeze protection is mandatory.
- Installation of filter at chiller inlet is mandatory.
- Performance of the unit are available with Water, Ethylene glycol and Propylene glycol. In case different substance is required, contact factory to evaluate compatibility and performances.
- All data and information on unit operation are referred to the unit installed in compliance with Installation requirements (refer to Installation and Operation manual).
- Installation conditions may have impact on the above operating conditions, refer to Daikin representative for confirmation.
- Unit options and/or special execution may affect operating limit. Contact factory for specific information.
- All data and information are subject to change without notice. Always refer to latest information available from factory on project base.

11. Water Quality

Water quality requirements	
Ph (25 °C)	7.5 – 9.0
Electrical conductivity [$\mu\text{S}/\text{cm}$] (25°C)	< 500
Chloride ion [$\text{mg Cl}^- / \text{l}$]	< 70 (HP ¹) < 300 (CO ²)
Sulphate ion [$\text{mg SO}_4^{2-} / \text{l}$]	< 100
Alkalinity [$\text{mg CaCO}_3 / \text{l}$]	< 200
Total Hardness [$\text{mg CaCO}_3 / \text{l}$]	75 ÷ 150
Iron [$\text{mg Fe} / \text{l}$]	< 0.2
Ammonium ion [$\text{mg NH}_4^+ / \text{l}$]	< 0.5
Silica [$\text{mg SiO}_2 / \text{l}$]	-
Chlorine molecular ($\text{mg Cl}_2/\text{l}$)	< 0.5

The values above are intended as guidelines and not exhaustive for a complete analysis on compatibility with unit component.

All data and information are subject to change without notice. Always refer to latest information available from factory on project base.

12. Hydraulics

12.1 Heat exchangers water volume and connection size

Model	Evaporator Volume [lt]	Evaporator Connection size [mm/inch]	Condenser Volume [lt]	Condenser Connection size [mm/inch]
EWWT100Q-X-A1	9,45	88,9	9,45	88,9
EWWT125Q-X-A1	11,07	88,9	11,07	88,9
EWWT160Q-X-A1	14,85	88,9	14,85	88,9
EWHT100Q-X-A1	9,45	88,9	9,45	88,9
EWLT100Q-X-A1	9,45	88,9	NA	NA
EWLT125Q-X-A1	11,07	88,9	NA	NA
EWLT160Q-X-A1	14,85	88,9	NA	NA

12.2 Module

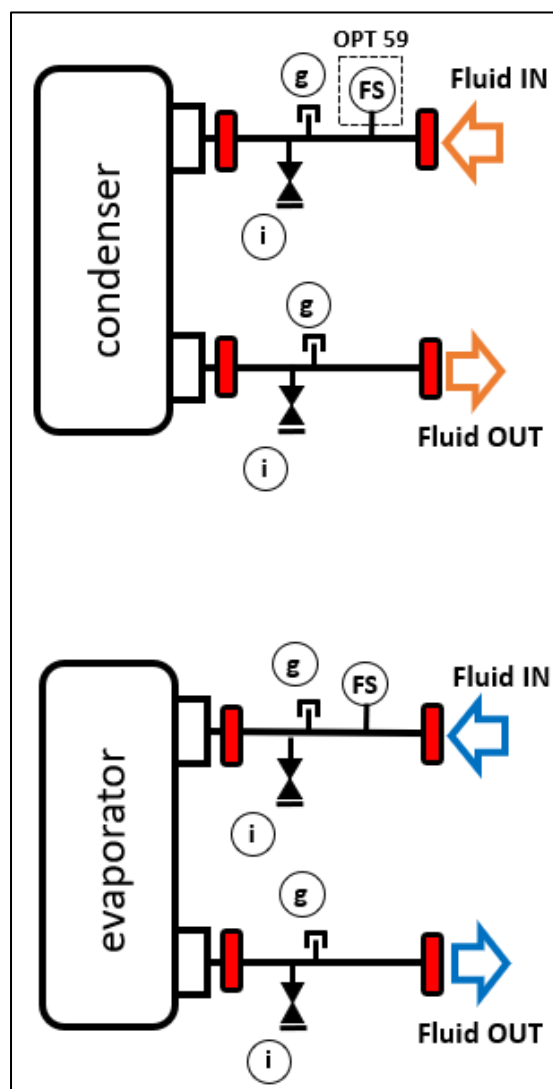

Legend	
g	Plugged Fitting ¼" NPT
FS	Flow Switch
i	Drain ½" NPT

NOTE:
 installation of filter upstream is mandatory.
 Circuit must be protected from freezing.

12.3 Module with manifold kit

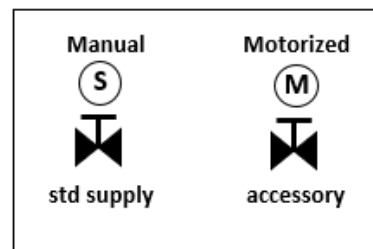
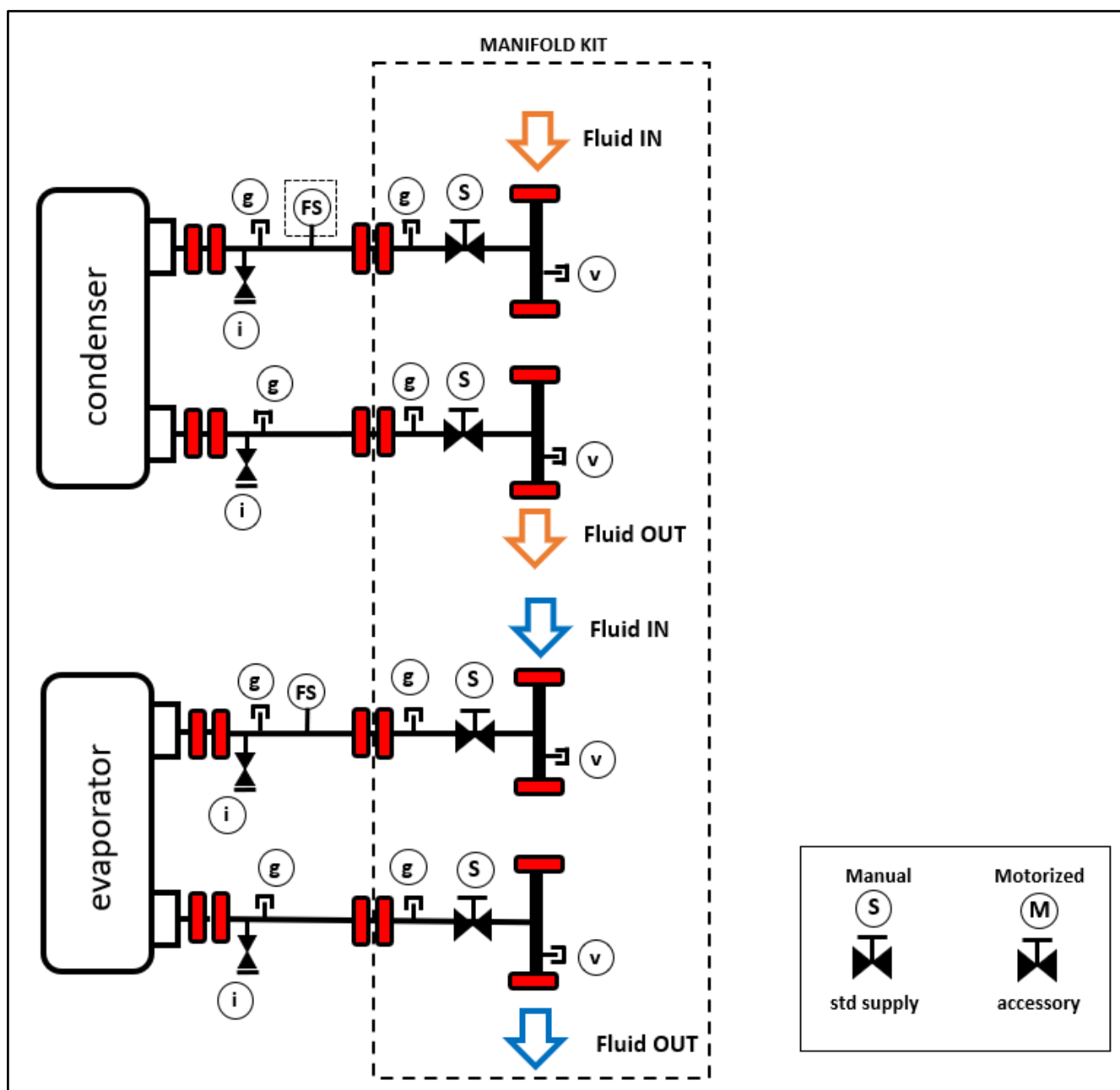

Legend	
g	Plugged Fitting ¼" NPT
FS	Flow Switch
i	Drain ½" NPT
s	Isolating valve. Standard with Manual control, motorized actuator available as accessory
v	Probe socket

NOTE:

installation of filter upstream is mandatory.
Circuit must be protected from freezing.

12.4 Pump module

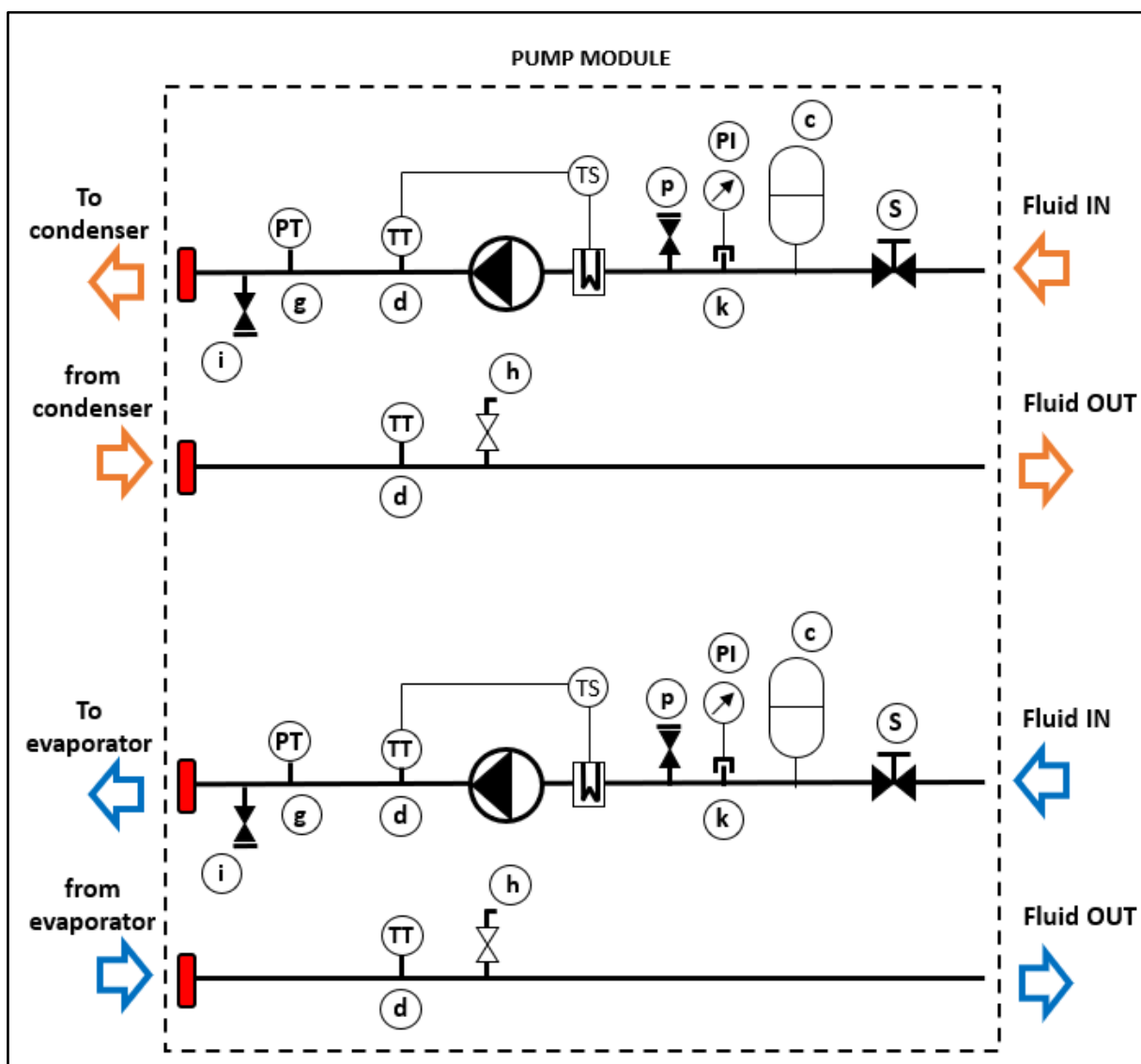

Legend	
g	Plugged Fitting 1/4" NPT
TT	Temperature Transducer
i	Drain 1/2" NPT
s	Isolating valve.
c	Expansion tank 18 lt
PT	Pressure transducer
TS	Temperature switch
PI	Pressure gauge
h	Air vent
k	Electrical heater
d	Plugged fitting 1/2" NPT

NOTE:
 installation of filter and flow switch is mandatory.
 Circuit must be protected from freezing.

12.5 Pump Modules technical data

Models	Type	Qty	Evaporator Pump		Condenser Pump	
			Power Input [kW]	Max Current [A]	Power Input [kW]	Max Current [A]
EKPUMPLL1	Low Lift	1+1	2,2	4,6	3,0	6,3
EKPUMPLL2	Low Lift	1+1	4,0	7,8	5,5	10,5
EKPUMPLL3	Low Lift	1+1	4,0	7,8	5,5	10,5
EKPUMPLL4	Low Lift	1+1	5,5	10,5	5,5	10,5
EKPUMPHL1	High Lift	1+1	4,0	7,8	4,0	7,8
EKPUMPHL2	High Lift	1+1	7,5	14,1	7,5	14,1
EKPUMPHL3	High Lift	1+1	7,5	14,1	7,5	14,1
EKPUMPHL4	High Lift	1+1	9,2	17,4	11,0	20,2

i) The above data are referred to the unit without additional optional.

ii) Pump performances are valid for liquids with density $\rho = 1,0 \text{ Kg/dm}^3$ and kinematic viscosity $\nu = 1 \text{ mm}^2/\text{sec}$.

iii) All the data are subject to change without notice. For updated information on project base refer to Chiller Selection Software and unit's certified drawing

- (1) Standard Rating Conditions for Air to water chillers according to EN14511:2 Outdoor Heat exchanger inlet dry bulb temperature 35°C at sea level; Indoor heat exchanger inlet water temperature 12°C, outlet water temperature 7°C. Fluid: water, Fouling factor = 0
- (2) Fluid: water, not including filter pressure drop. The installation of the filter is mandatory.
- (3) 400V power supply with $\pm 10\%$ tolerance on Voltage, Voltage unbalance between phases must be within $\pm 3\%$
 - Pump motor protection IP55
 - Pump motor Insulation Class F

NOTE: In case of use with brine mixture contact factory

13. Heat recovery

EW(W)(H)T Q- A can be equipped with partial heat recovery capability.

The heat recovery exchange is Brazed Plate type. Refer to unit drawing for heat exchanger position and connections.

The water contents for the heat recovery exchangers and connections size are listed in the below tables:

Partial Heat Recovery Brazed Plate Heat Exchanger		
Model	Volume [lt]	Connection size [mm inch]
EWWT100Q-XSA1	4,8	60,3 2 3/8
EWWT125Q-XSA1	5,3	60,3 2 3/8
EWWT160Q-XSA1	7,6	60,3 2 3/8
EWHT100Q-XSA1	4,8	60,3 2 3/8
EWLT100Q-XSA1	NA	60,3 2 3/8
EWLT125Q-XSA1	NA	60,3 2 3/8
EWLT160Q-XSA1	NA	60,3 2 3/8

All above data are subject to change without notice.

14. Installation notes

Installation and maintenance of the unit must be performed only by qualified personnel who have knowledge with local codes and regulations, and experience with this type of equipment. Avoid installation in places that could be considered dangerous for all the maintenance operations.

Care should be taken to avoid rough handling or shock due to dropping the unit. Do not push or pull the unit from anything other than the base frame. Never allow the unit to fall during unloading or moving as this may result in serious damage. To lift the unit, rings are provided in the base frame of the unit. All units have holes in the base frame. Only these points may be used for lifting the unit. The unit can be handled and lifted with a pallet truck if wooden spacers are present. The handling and lifting with a forklift are the only rigging methods using the base frame's holes.

The standard sound version (XS) are produced for indoor installation. Reduced sound version (XR) are suitable for outdoor installation.

The unit must be installed on a sturdy and perfectly level foundation. For installation on the ground, a resistant concrete base must be created with a width greater than that of the unit. This base must be able to support its weight.

The frame of the unit must be perfectly levelled during installation, if necessary, using shims to be inserted under the anti-vibration elements.

Respect the minimum access distances 1000 mm all around the unit.

The above values are general guidelines. When consider unit installation is fundamental to consider proper clearances around the unit to perform all possible maintenance activities and replacing of unit's components in respect of safety standard. Deviation from guidelines should be evaluated by local service provider.

Refer to Installation and Operation Manual for details on storage, handling, and installation of the unit.

15. Dimensional drawings

LEGENDA/LEGEND

- 1-COMPRESSORE
COMPRESSOR
- 2-EVAPORATORE
EVAPORATOR
- 3-CONDENSATORE
CONDENSER
- 4-PANNELLO DI COMANDO E CONTROLLO
OPERATING AND CONTROL PANEL
- 5-CONNESSIONE INGRESSO ACQUA EVAPORATORE DIA. 88,9 (VITALLIC)
EVAPORATOR WATER INLET CONNECTION DIA. 88,9 (VITALLIC)
- 6-CONNESSIONE USCITA ACQUA EVAPORATORE DIA. 88,9 (VITALLIC)
EVAPORATOR WATER OUTLET CONNECTION DIA. 88,9 (VITALLIC)
- 7-CONNESSIONE INGRESSO ACQUA CONDENSATORE DIA. 88,9 (VITALLIC)
CONDENSER WATER INLET CONNECTION DIA. 88,9 (VITALLIC)
- 8-CONNESSIONE USCITA ACQUA CONDENSATORE DIA. 88,9 (VITALLIC)
CONDENSER WATER OUTLET CONNECTION DIA. 88,9 (VITALLIC)
- 9-FORO INGRESSO ALIMENTAZIONE
POWER CONNECTIONS HOLE
- 10-FORODIA. 25mm PER MONTAGGIO ANTIVIBRANTI
ISOLATOR MOUNTING HOLES DIA. 25mm
- 11-CABINA INSONORIZZANTE - OPZIONALE
SOUNDPROOF CABINET (OPTIONAL)
- 12-KIT CONNESSIONE INGRESSO ACQUA LATO ACQUA (OPZIONALE SPEDITO A CORREDO)
KIT WATER INLET / SHIPPED LOGE (OPTIONAL)

SCALA 1:50
SCALE 1:50

DISPOSIZIONE ANTIVIBRANTI (VISTA DAL BASSO)
ISOLATOR LOCATOR (BOTTOM VIEW)

SCALA 1:50
SCALE 1:50

1200 mm (for broken configuration)

SPAZIO MINIMO NECESSARIO MANUTENZIONE
MINIMUM REQUIRED MAINTENANCE

UNITA' UNIT	VERSIONE VERSION	PESO UNITA' (kg) UNIT WEIGHT (kg)		CENTRO DI GRAVITA' (SOLO TRASPORTO) CENTER OF GRAVITY (SHIPPING ONLY)			CARICHI ANTIVIBRANTI (kg) ISOLATOR LOADS (kg)			
		SPEDIZIONE SHIPPING	FUNZIONAMENTO OPERATING	X	Y	Z	A	B	C	D
EWWT1000-X	SA1	419	439	585	559	480	106	133	99	101
	RA1	470	490	601	563	503	118	140	112	120
EWWT1250-X	SA1	469	491	585	589	493	127	139	115	110
	RA1	520	542	600	590	512	139	147	128	128
EWWT1600-X	SA1	531	561	588	557	496	132	166	130	131
	RA1	582	612	601	561	515	148	172	141	151

CABINA INSONORIZZANTE (OPZIONALE)
SOUNDPROOF CABINET (OPTIONAL)

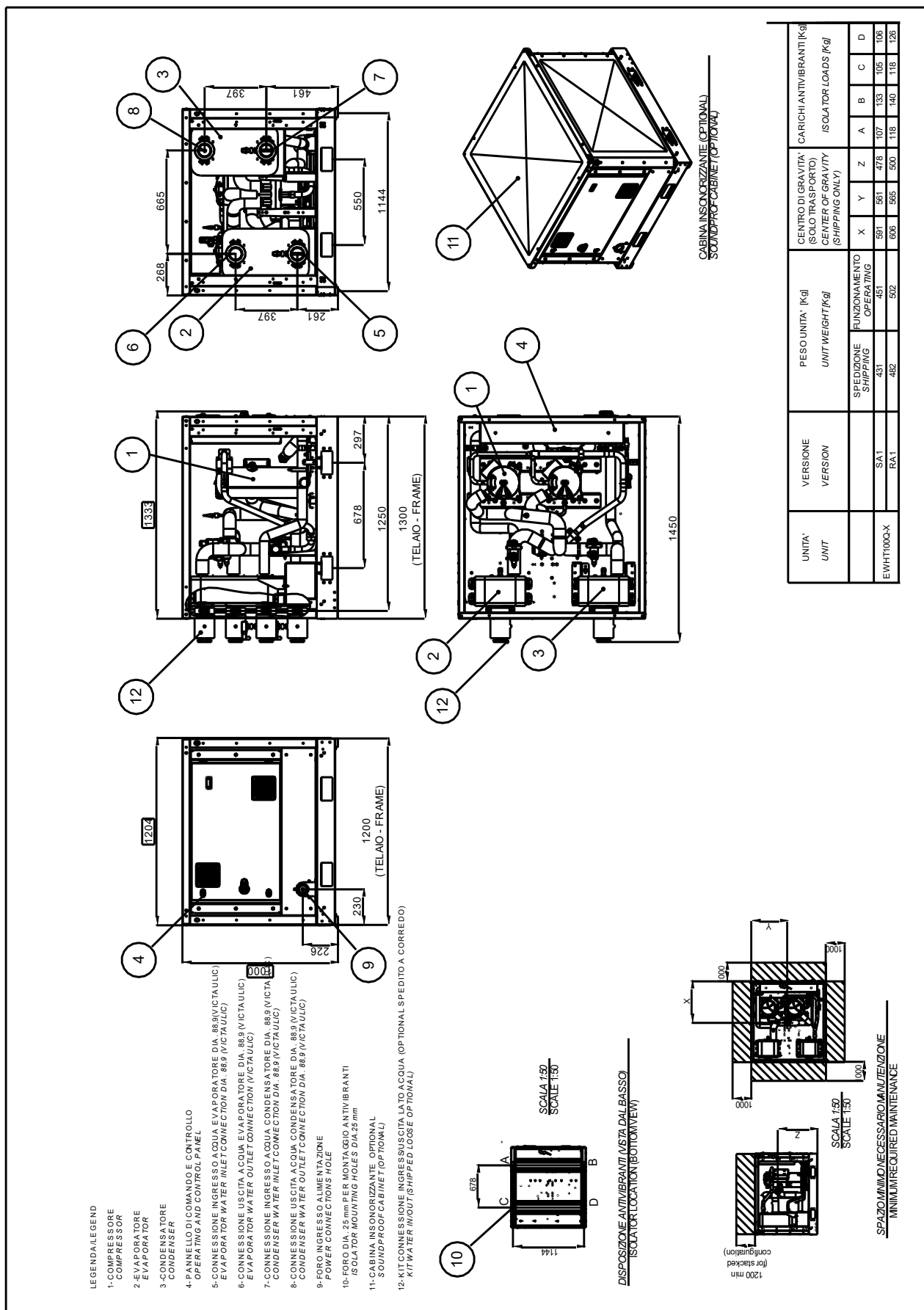

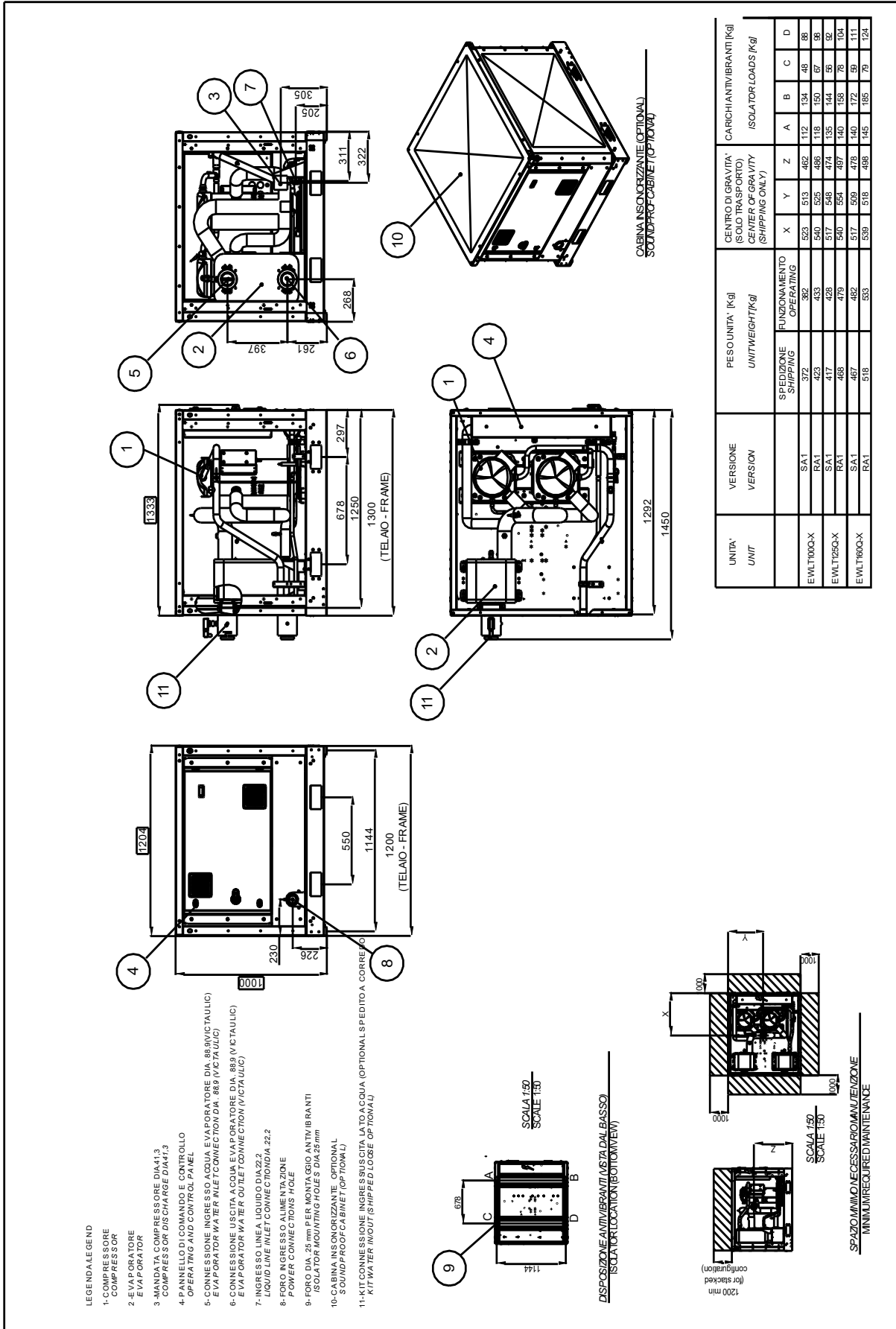

16. Technical Specifications

General information

The chiller will be designed and manufactured in accordance with the following European directives:

- Construction of pressure vessel 2014/68/EU
- Machinery Directive 2006/42/EC
- Low Voltage 2014/35/EU
- Electromagnetic Compatibility 2014/30/EU
- Harmonized standard EN 60204–1 Safety of Machinery
- Manufacturing Quality Standards UNI – UNI EN 14000

The unit will be tested at full load in the factory (at the nominal working conditions and water temperatures). The chiller will be delivered to the job site completely assembled and charged with refrigerant and oil. The installation of the chiller must comply with the manufacturer’s instructions for rigging and handling equipment.

The unit will be able to start up and operate (as standard) at full load with:

- Condenser leaving fluid temperature between..... °C and..... °C
- Evaporator leaving fluid temperature between..... °C and..... °C

Refrigerant HFC R-32

Performance

Chiller shall supply the following performances:

Number of Chiller(s)		unit(s)
Fluid		type
Cooling capacity for single chiller		kW
Power input for single chiller		kW
Evaporator Entering Temperature (EET)		°C
Evaporator Leaving Temperature (ELT)		°C
Evaporator Water Flow rate		l/s
Condenser Entering Temperature (CET)		°C
Condenser Leaving Temperature (CLT)		°C
Condenser Water Flow rate		l/s
Minimum full load efficiency (EER)		kW/kW
Minimum part load efficiency (SEER)		kW/kW
Minimum part load efficiency (SEPR)		kW/kW
Minimum part load efficiency (IPLV)		kW/kW
Minimum part load efficiency (ESEER)		kW/kW

Operating voltage range should be 400V ±10%, 3ph, 50Hz, voltage unbalance maximum 3%, without neutral conductor.

Unit description

The unit shall include as standard: one refrigerant circuit per module, each of them equipped with an hermetic type rotary scroll compressors, thermal expansion device, refrigerant direct expansion plate to plate heat exchangers, R32 refrigerant, motor starting components, control system and all components necessary for a safe and stable unit operation. The unit will be factory assembled on a robust base frame made of galvanized steel, protected by epoxy paint.

Sound level and vibrations

Sound power level shall not exceeddB(A). The sound power levels must be rated in accordance with ISO 9614 (other types of rating cannot be used).

Dimensions

Unit dimensions shall not exceed following indications:

- Unit length..... mm
- Unit width..... mm
- Unit height..... mm

Compressors

The units shall be equipped with:

High performance hermetic scroll compressors optimized to work with R32, with reduced vibration and sound emissions.

- High efficiency values shall be guaranteed by:
 - High volumetric efficiency in the whole range of application, through the continuous contact between the fixed and the orbiting scroll deleting the dead space and the re-expansion of the refrigerant gas;
 - Low pressure drops due to the absence of inlet and discharge valves and to the uniform compression cycle;
 - Reduction of the heat exchange between the gas during suction and discharge due to the separation of gas flows;
- The reduced noise shall be obtained by:
 - The absence of the inlet and discharge valves
 - The uniform compression cycles
 - The absence of pistons which ensures reduced vibration and pulsation of the refrigerant
- The engine shall be cooled by the suction refrigerant fluid.
- Shall be present a thermal protection for the three phases complete with sensors on the stator windings to avoid overheating caused by lack of phase, insufficient cooling, mechanical locks, power supply out of tolerance;
- The compressors shall be fitted on rubber antivibration mounts.
- The compressors shall be provided complete with oil charge.

Evaporator (PHE) The units shall be equipped with a direct expansion plate to plate type evaporator. The evaporator will be made of stainless steel brazed plates closed cell with thermal insulation material.

- The evaporator will have 1 refrigerant circuit.
- The evaporator will be manufactured in accordance to PED approval.
- Flow switch must be installed on plant.
- Water filter must be installed on plant.

Condenser (PHE) The units shall be equipped with a plate to plate type condenser. The condenser will be made of stainless steel brazed:

- The condenser will have 1 refrigerant circuit.
- The condenser will be manufactured in accordance to PED approval.
- Water filter must be installed on plant.

Refrigerant circuit The unit shall have one refrigerant circuit per module according to the capacity.

- The circuit shall include as standard the following safety devices: High and low pressure switch, hot gas temperature monitoring, overload relay.

Electrical control panel Power and control Power and control sections shall be located into the main electrical panel. The power section shall include Main switch, auxiliary and control cut-outs, transformers, control fuses, relay and auxiliary relay, sensors, unit digital controller. The main panel doors shall be interlocked to the main switch to guarantee safe operations when the doors are open.

Controller

The controller will be installed as standard and it will be used to modify unit set-points and check control parameters.

- A sophisticated software with predictive logic, will select the most energy efficient combination of compressors and EEXV to keep stable operating conditions to maximize unit energy efficiency and reliability;
- The controller will be able to protect critical components based on external signals received from the unit itself.

Controller features

Controller shall be guarantee following minimum functions:

- Management of the compressors;
- Full routine operation at condition of high evaporator entering water temperature (start-up);
- Leaving water evaporator temperature regulation;
- Display of Status Safety Devices;
- Number of starts and compressor working hours;
- Optimized management of unit load;
- Start at high evaporator water temperature;
- Master / Slave (provided as standard) ;
- Variable primary Flow (available as accessory).

The present document is drawn up by way of information only and does not constitute an offer binding upon Daikin Applied Europe. Daikin Applied Europe has compiled the content of this document to the best of its knowledge. No express or implied warranty is given for the completeness, accuracy, reliability of fitness to particular purpose of its content and the products and services presented therein. Specifications are subject to change without prior notices. Daikin Applied Europe explicitly rejects any liability for any direct or indirect damage, in the broadest sense, arising from or related to the use and/or interpretation of this document.

Daikin Applied Europe S.p.A.

Società unipersonale soggetta ad attività di direzione e coordinamento di Daikin Industries Ltd

Sede Legale: Via Piani di S. Maria, 72
00040 Ariccia (Roma), Italia

Sede Amm.va: S.S. Nettunense Km 12+300
00040 Cecchina (Roma), Italia

T +39 06 93 73 11
F +39 06 93 74 0 14

